

## World Shooting Para Sport

Appendices 1-~~12~~11



## Table of contents

<u>Appendix Number</u>	<u>Page Numbers</u>
Appendix 1 – <del>Table of</del> Requirements & <del>Competition</del> Designation <a href="#">of Competitions</a>	2-6
Appendix 2 – <del>Approved</del> <a href="#">Recognised</a> Competition Requirements	7- <del>8</del> <u>12</u>
Appendix 3 – Sanctioned & <a href="#">Approved</a> Competition Requirements	<del>9-15</del> <u>13-20</u>
Appendix 4 – Bib Templates	<del>16-17</del> <u>21-22</u>
Appendix 5 – Equipment Control Sheet	<del>18</del> <u>23</u>
Appendix 6 – Trigger Extension & Adaptations	<del>19-22</del> <u>24-27</u>
Appendix 7 – SH2 Support Stands & <del>Parts Drawings</del> <a href="#">Springs</a>	<del>23-25</del> <u>28-32</u>
Appendix 8 – P5 10m Air Pistol Standard	<del>26-31</del> <u>33-37</u>
<del>Appendix 9 – Falling Target Draw Programme</del>	<del>32</del>
Appendix <del>10</del> <u>9</u> – Athlete Epilepsy Declaration	<del>33</del> <u>38</u>
Appendix <del>11</del> <u>10</u> – VI Shooting Technical Specifications	<del>34-37</del> <u>39-42</u>
Appendix <del>12</del> <u>11</u> – Mixed Team Competitions	<del>38-43</del> <u>51</u>

### International Paralympic Committee

Adenauerallee 212-214 Tel. +49 228 2097-195  
53113 Bonn, Germany Fax +49 228 2097-209

<https://www.paralympic.org/shooting>

# APPENDIX Appendix 1

Requirements and designation & Designation of competitions Competitions

## 1 General requirements

	<b>Level 3</b> <del>IPC competitions</del> IPC Games and Shooting Para Sport World Championships	<b>Level 2</b> World Shooting Para Sport (WSPS) Sanctioned Competitions <del>(World Cup)</del>	<b>Level 1</b> World Shooting Para Sport (WSPS) Approved Competitions <del>(Grand Prix)</del>
<b>Legal terms of reference</b>	<del>Host Contract</del> Hosting agreement, Memorandum <del>Of of</del> Understanding (MOU) <del>as applicable</del>	Application and <del>Agreement of</del> Competition Guidelines <del>hosting agreement</del>	Competition <del>Application</del> application
<b>Athlete licensing</b>	All participating athletes must <del>be licensed</del> have a WSPS License	All participating athletes must <del>be licensed</del> have a WSPS License	All participating athletes must <del>be licensed</del> have a WSPS License
<b>Results recognition</b>	Results are recognised for MQS, <del>Rankings</del> rankings and <del>Records</del> records	Results are recognised for MQS, <del>Rankings</del> rankings and <del>Records</del> records	Results are recognised for MQS, but are <b>not</b> recognised for <del>Rankings</del> rankings or <del>Records</del> records
<b>Fee</b>	Application and Signing fees	Sanctioning fee	Approval fee
<b>Officiating</b>	Technical Delegate required, full panel of <del>International Technical Officials</del> Competition Jury required	Technical Delegate required, full panel of <del>International Technical Officials</del> Competition Jury required	Technical Delegate/Chief Judge required; panel of <del>International Technical Officials</del> Competition Jury as prescribed
<b>Results, Timing, Scoring (RTS)</b>	Full <del>International</del> international panels required	Full <del>International</del> international panels required, or as prescribed by <del>World Shooting Para Sport</del> WSPS	Full <del>International</del> international panels preferred, or as prescribed by <del>World Shooting Para Sport</del> WSPS
<b>Doping control</b>	IPC results management subject to Doping Control Agreement	IPC results management subject to Doping Control Agreement	Run under National Jurisdiction or <del>Major Event Organiser</del> LOC Jurisdiction, <del>Education</del> education encouraged
<b>Media and communications</b>	Service Level Agreement between <del>IPC</del> WSPS and LOC	<del>Service Level Agreement between IPC and LOC</del> As defined in the host agreement	No set requirements

# APPENDIX Appendix 1

## Requirements and Designation of Competitions

<b>Broadcasting</b>	(PG) – Games Broadcasting strategy applies (WCH, RCH) – Broadcasting agreement between <a href="#">IPC/WSPS</a> and LOC	<del>Broadcasting</del> <a href="#">Live stream to be provided by the LOC as defined in the hosting agreement between IPC and LOC, where applicable</a>	No set requirements
	<a href="#">Level 3-IPC Games and World Championships</a>	<a href="#">World Cup</a> <del>Level 2</del>	<a href="#">Grand Prix</a> <del>Level 1</del>
<b>Branding</b>	(PG) - Games Branding policies (WCH,RCH) – Branding guidelines apply, <a href="#">World Shooting Para Sport/WSPS</a> logo, branding and official <del>competition</del> <a href="#">Competition</a> title usage is mandatory	Branding guidelines apply. Usage of <a href="#">World Shooting Para Sport/WSPS</a> logo, branding, and official <del>competition</del> <a href="#">Competition</a> title (“[City][Year] <a href="#">World Shooting Para Sport [World Cup/Grand Prix]”)”) is mandatory</a>	“ <del>World Shooting Para Sport Approved Competition</del> <a href="#">WSPS Grand Prix</a> ” alongside the <del>competition</del> <a href="#">Competition</a> name
<b>Commercial rights</b>	(PG) – Games <del>Marketing</del> <a href="#">marketing conditions</a> apply (WCH, RCH) – Commercial rights granted to LOC <a href="#">pursuant to hosting agreement</a> , LOC to offer first right of <del>refuse IPC</del> <a href="#">refusal to WSPS</a> partners, <a href="#">IPC/WSPS</a> retains_% of <a href="#">Marketing</a> <del>marketing</del> inventory	Commercial rights granted to LOC <a href="#">pursuant to hosting agreement</a> , LOC to offer first right of <del>refuse IPC</del> <a href="#">refusal to WSPS</a> partners, <a href="#">IPC/WSPS</a> retains% <a href="#">a percentage</a> of <a href="#">Marketing</a> <del>the marketing</del> inventory	No set requirements
<b>Publications</b>	<del>To be approved</del> (PG) - <a href="#">As determined by IPC</a> (WCH, RCH) - <a href="#">As determined</a> by WSPS	To be approved by WSPS	No set requirements but <del>should</del> <a href="#">must</a> be approved by WSPS where <a href="#">possible</a> <del>applicable</del>
<b>Protocol</b>	<del>Protocol Guidelines apply</del> (PG) - <a href="#">As determined by IPC</a> (WCH, RCH) - <a href="#">As determined</a> by WSPS	<del>Protocol Guidelines apply</del> <a href="#">As determined by WSPS</a>	No set requirements <a href="#">but must be approved by WSPS where applicable</a>

# APPENDIX Appendix 1

## Requirements and designation & Designation of competitions Competitions

<b>Services</b>	Standards apply as set out in Manuals, Guidelines and/or MOU	Standards apply as set out in Competition Guidelines	Standards set by LOC
<b>Look</b>	<del>To be directed and (PG) - As determined by IPC (WCH, RCH) - As approved by IPC</del> <u>WSPS</u>	To be approved by <u>IPC WSPS</u>	No set requirements
<b>Technology</b> <u>OVR = On Venue Results</u>	PRIS requirements apply, OVR must be supplied through Games or <u>World Shooting Para Sport WSPS</u> supplier	OVR must be supplied through <u>World Shooting Para Sport WSPS</u> supplier	OVR supplied through LOC's Competition supplier
<b>Research</b>	<del>IPC Research protocols apply</del>	<del>IPC Research protocols apply</del>	<del>IPC Research protocols apply</del>

## 2 Specific requirements

	<u>Level 3</u> IPC <del>competitions</del> <u>Games and World Championships</u>	<u>Level 2</u> <u>World Shooting Para Sport Sanctioned Competitions World Cups</u>	<u>Grand Prix</u> <u>Level 1</u> <u>World Shooting Para Sport Approved Competitions</u>
	<i>Paralympic Games</i>	<i>World / Regional Championships</i>	<i>World Cups / or Regional Games</i> <del>Grand Prix</del> <u>Grand Prix International Competitions</u>
<b>Events programme</b>	Set by <u>World Shooting Para Sport WSPS/IPC</u>	<u>Programme 1 is mandatory All WSPS Events</u>	<u>World Cup: Programme 1</u> <u>Grand Prix: Programme 2 or 3</u> <u>All Paralympic Events, optional additional Events</u>
<b>Entry level</b>	Direct Slots 2 MQS for 1st <u>event</u> <u>Event</u> 1MQS for additional event(s)	1 MQS per <u>event</u> <u>Event</u>	No MQS required
<b>Event viability (min.</b>	No less than 4 per	<del>No</del> <u>Individual Event: no</u>	Individual <u>events</u> <u>Events</u> : no less than 4; No less than 3 per <u>event</u> <u>Event</u>

# APPENDIX Appendix 1

## Requirements and Designation of Competitions

number of countries per event	event	less than 4 per event; Team events: no less than 3	Team events: no less than 3	
Output	Results Records Rankings MQS	Results Records Rankings MQS <u>Direct Slots (World Championships)</u>	Results Records Rankings MQS <u>Direct Slots (if World Cup is designated for Paralympic Direct Allocation)</u>	Results  MQS
Finals	In all events	In all Paralympic events, VI and Para Trap	In all Paralympic events, VI and Para Trap	In all Paralympic events, VI and Para Trap
Electronic targets and results services from Official Target and Results Provider	Mandatory	Mandatory	Mandatory	Optional

	<u>Level 3 (Paralympic Games)</u>	<u>Level 3 (World / Regional Championships)</u>	<u>Level 2 World Cups</u>	<u>Level 1 Grand Prix</u>
Technical Delegate	Mandatory	Mandatory	Mandatory	Programme 1: Mandatory Programme 2/3: only Chief Judge

# APPENDIX Appendix 1

## Requirements and designation & Designation of competitions Competitions

International Technical Officials (ITOs)	<table border="1"> <thead> <tr> <th>Role</th> <th>No. of ITOs</th> </tr> </thead> <tbody> <tr> <td>Technical Delegate</td> <td>1</td> </tr> <tr> <td><a href="#">Chief of Jury</a></td> <td><u>1</u></td> </tr> <tr> <td>Pistol Jury</td> <td>3</td> </tr> <tr> <td>Rifle Jury</td> <td>3</td> </tr> <tr> <td>Equipment Control Jury</td> <td><u>12</u></td> </tr> <tr> <td>RTS Jury</td> <td>3</td> </tr> <tr> <td><a href="#">Jury of Appeal</a></td> <td>1</td> </tr> <tr> <td><b>Total Appointed Byby WSPS:</b></td> <td><b><u>1214</u></b> ITOs</td> </tr> </tbody> </table>	Role	No. of ITOs	Technical Delegate	1	<a href="#">Chief of Jury</a>	<u>1</u>	Pistol Jury	3	Rifle Jury	3	Equipment Control Jury	<u>12</u>	RTS Jury	3	<a href="#">Jury of Appeal</a>	1	<b>Total Appointed Byby WSPS:</b>	<b><u>1214</u></b> ITOs	<table border="1"> <thead> <tr> <th>Role</th> <th>No. of ITOs</th> </tr> </thead> <tbody> <tr> <td>Technical Delegate</td> <td>1</td> </tr> <tr> <td><a href="#">Chief of Jury</a></td> <td><u>1</u></td> </tr> <tr> <td>Pistol Jury</td> <td>3</td> </tr> <tr> <td>Rifle Jury</td> <td>3</td> </tr> <tr> <td><a href="#">Para Trap Jury</a></td> <td><u>2</u></td> </tr> <tr> <td>Equipment Control Jury</td> <td><u>12</u></td> </tr> <tr> <td>RTS Jury</td> <td>3</td> </tr> <tr> <td><a href="#">Jury of Appeal</a></td> <td><u>1</u></td> </tr> <tr> <td><b>Total Appointed Byby WSPS:</b></td> <td><b><u>12*15</u></b> ITOs</td> </tr> </tbody> </table> <p><i>*Final number may vary and will be determined by WSPS depending on the range size and competition requirements</i></p>	Role	No. of ITOs	Technical Delegate	1	<a href="#">Chief of Jury</a>	<u>1</u>	Pistol Jury	3	Rifle Jury	3	<a href="#">Para Trap Jury</a>	<u>2</u>	Equipment Control Jury	<u>12</u>	RTS Jury	3	<a href="#">Jury of Appeal</a>	<u>1</u>	<b>Total Appointed Byby WSPS:</b>	<b><u>12*15</u></b> ITOs	<p><b>World Cup:</b></p> <table border="1"> <thead> <tr> <th>Role</th> <th>No. of ITOs</th> </tr> </thead> <tbody> <tr> <td>Technical Delegate</td> <td>1</td> </tr> <tr> <td><a href="#">Chief of Jury</a></td> <td><u>1</u></td> </tr> <tr> <td>Pistol Jury</td> <td>2</td> </tr> <tr> <td>Rifle Jury</td> <td>2</td> </tr> <tr> <td><a href="#">Para Trap Jury</a></td> <td><u>2</u></td> </tr> <tr> <td>Equipment Control Jury</td> <td><u>12</u></td> </tr> <tr> <td>RTS Jury</td> <td>2</td> </tr> <tr> <td><a href="#">Chair of Juries</a></td> <td><u>1</u></td> </tr> <tr> <td><b>Total Appointed Byby WSPS:</b></td> <td><b><u>9*12</u></b> ITOs</td> </tr> </tbody> </table> <p><i>*Final number may vary and will be determined by WSPS depending on the range size and competition requirements</i></p> <p><b>Grand Prix:</b></p> <table border="1"> <thead> <tr> <th>Role</th> <th>No. of ITOs</th> </tr> </thead> <tbody> <tr> <td>Technical Delegate</td> <td><u>1</u></td> </tr> <tr> <td>Combined Jury</td> <td>2</td> </tr> <tr> <td><b>Total Appointed By WSPS:</b></td> <td><b><u>3</u></b> ITOs</td> </tr> </tbody> </table>	Role	No. of ITOs	Technical Delegate	1	<a href="#">Chief of Jury</a>	<u>1</u>	Pistol Jury	2	Rifle Jury	2	<a href="#">Para Trap Jury</a>	<u>2</u>	Equipment Control Jury	<u>12</u>	RTS Jury	2	<a href="#">Chair of Juries</a>	<u>1</u>	<b>Total Appointed Byby WSPS:</b>	<b><u>9*12</u></b> ITOs	Role	No. of ITOs	Technical Delegate	<u>1</u>	Combined Jury	2	<b>Total Appointed By WSPS:</b>	<b><u>3</u></b> ITOs	<p><b>Programme 1 Grand Prix:</b></p> <table border="1"> <thead> <tr> <th>Role</th> <th>No. of ITOs</th> </tr> </thead> <tbody> <tr> <td>Technical Delegate (Jury of Appeal Chief Judge)</td> <td>1</td> </tr> <tr> <td>Combined Jury</td> <td>2</td> </tr> <tr> <td><a href="#">Para Trap Jury</a></td> <td><u>1</u></td> </tr> <tr> <td><b>Total Appointed Byby WSPS:</b></td> <td><b><u>34</u></b> ITOs</td> </tr> </tbody> </table> <p><b>Programme 2 or 3:</b></p> <table border="1"> <thead> <tr> <th>Role</th> <th>No. of ITOs</th> </tr> </thead> <tbody> <tr> <td>Chief Judge</td> <td><u>1</u></td> </tr> <tr> <td>Combined Jury</td> <td>2</td> </tr> <tr> <td><b>Total Appointed By WSPS:</b></td> <td><b><u>3</u></b> ITOs</td> </tr> </tbody> </table>	Role	No. of ITOs	Technical Delegate (Jury of Appeal Chief Judge)	1	Combined Jury	2	<a href="#">Para Trap Jury</a>	<u>1</u>	<b>Total Appointed Byby WSPS:</b>	<b><u>34</u></b> ITOs	Role	No. of ITOs	Chief Judge	<u>1</u>	Combined Jury	2	<b>Total Appointed By WSPS:</b>	<b><u>3</u></b> ITOs
	Role	No. of ITOs																																																																																						
Technical Delegate	1																																																																																							
<a href="#">Chief of Jury</a>	<u>1</u>																																																																																							
Pistol Jury	3																																																																																							
Rifle Jury	3																																																																																							
Equipment Control Jury	<u>12</u>																																																																																							
RTS Jury	3																																																																																							
<a href="#">Jury of Appeal</a>	1																																																																																							
<b>Total Appointed Byby WSPS:</b>	<b><u>1214</u></b> ITOs																																																																																							
Role	No. of ITOs																																																																																							
Technical Delegate	1																																																																																							
<a href="#">Chief of Jury</a>	<u>1</u>																																																																																							
Pistol Jury	3																																																																																							
Rifle Jury	3																																																																																							
<a href="#">Para Trap Jury</a>	<u>2</u>																																																																																							
Equipment Control Jury	<u>12</u>																																																																																							
RTS Jury	3																																																																																							
<a href="#">Jury of Appeal</a>	<u>1</u>																																																																																							
<b>Total Appointed Byby WSPS:</b>	<b><u>12*15</u></b> ITOs																																																																																							
Role	No. of ITOs																																																																																							
Technical Delegate	1																																																																																							
<a href="#">Chief of Jury</a>	<u>1</u>																																																																																							
Pistol Jury	2																																																																																							
Rifle Jury	2																																																																																							
<a href="#">Para Trap Jury</a>	<u>2</u>																																																																																							
Equipment Control Jury	<u>12</u>																																																																																							
RTS Jury	2																																																																																							
<a href="#">Chair of Juries</a>	<u>1</u>																																																																																							
<b>Total Appointed Byby WSPS:</b>	<b><u>9*12</u></b> ITOs																																																																																							
Role	No. of ITOs																																																																																							
Technical Delegate	<u>1</u>																																																																																							
Combined Jury	2																																																																																							
<b>Total Appointed By WSPS:</b>	<b><u>3</u></b> ITOs																																																																																							
Role	No. of ITOs																																																																																							
Technical Delegate (Jury of Appeal Chief Judge)	1																																																																																							
Combined Jury	2																																																																																							
<a href="#">Para Trap Jury</a>	<u>1</u>																																																																																							
<b>Total Appointed Byby WSPS:</b>	<b><u>34</u></b> ITOs																																																																																							
Role	No. of ITOs																																																																																							
Chief Judge	<u>1</u>																																																																																							
Combined Jury	2																																																																																							
<b>Total Appointed By WSPS:</b>	<b><u>3</u></b> ITOs																																																																																							
Classification Panels	<p>Arrangement to be decided by World Shooting Para Sport. No Classification</p>	<p>Full panel compulsory (4 persons) plus Chief Classifier No Classification or The number is to be determined by</p>	<p>Arrangement The number is to be decided/determined by World Shooting Para Sport. the final entries</p>	<p>Arrangement Classification is optional. If yes, the number is to be decided/determined by World Shooting Para Sport. the final entries</p>																																																																																				

# APPENDIX Appendix 1

## Requirements and designation & Designation of competitions Competitions

		<a href="#">the final entries</a>																																						
	<del>Level 3 (Paralympic Games)</del>	<del>Level 3 (World / Regional Championships)</del>	<del>World Cup</del> <b>Level 2</b>	<b>Level 1</b> <del>Grand Prix</del>																																				
<b>Minimum number of days</b> (depending on range capacity)	<table border="1"> <tr> <td><b>Competition days:</b></td> <td>Min. 7 days</td> </tr> <tr> <td><b>Classification/ Equipment Control:</b></td> <td>2 days prior to <a href="#">competition</a> <a href="#">Competition</a></td> </tr> <tr> <td><b>TOTAL:</b></td> <td>Min. 9 days</td> </tr> </table>	<b>Competition days:</b>	Min. 7 days	<b>Classification/ Equipment Control:</b>	2 days prior to <a href="#">competition</a> <a href="#">Competition</a>	<b>TOTAL:</b>	Min. 9 days	<table border="1"> <tr> <td><b>Competition days:</b></td> <td>Min. 8 days</td> </tr> <tr> <td><b>*Classification/ Equipment Control:</b></td> <td>2 days prior to <a href="#">competition</a> <a href="#">Competition</a></td> </tr> <tr> <td><b>TOTAL:</b></td> <td>Min. 10 days</td> </tr> </table> <p><i>*Only for Regional Championships</i></p>	<b>Competition days:</b>	Min. 8 days	<b>*Classification/ Equipment Control:</b>	2 days prior to <a href="#">competition</a> <a href="#">Competition</a>	<b>TOTAL:</b>	Min. 10 days	<p><del>World Cup:</del></p> <table border="1"> <tr> <td><b>Competition days:</b></td> <td>Min. 5 days</td> </tr> <tr> <td><b>Classification / Equipment Control:</b></td> <td>2 days prior to <a href="#">competition</a> <a href="#">Competition</a></td> </tr> <tr> <td><b>TOTAL:</b></td> <td>Min. 7 days</td> </tr> </table> <p><del>Grand Prix:</del></p> <table border="1"> <tr> <td><b>Competition days:</b></td> <td>Min. 3 days</td> </tr> <tr> <td><b>Classification/ Equipment Control:</b></td> <td>2 days prior to competition</td> </tr> <tr> <td><b>TOTAL:</b></td> <td>Min. 5 days</td> </tr> </table>	<b>Competition days:</b>	Min. 5 days	<b>Classification / Equipment Control:</b>	2 days prior to <a href="#">competition</a> <a href="#">Competition</a>	<b>TOTAL:</b>	Min. 7 days	<b>Competition days:</b>	Min. 3 days	<b>Classification/ Equipment Control:</b>	2 days prior to competition	<b>TOTAL:</b>	Min. 5 days	<p><b>Programme 1:</b></p> <table border="1"> <tr> <td><b>Competition days:</b></td> <td>Min. 5 days</td> </tr> <tr> <td><b>Classification / Equipment Control:</b></td> <td>2 days prior to <a href="#">competition</a> <a href="#">Competition</a></td> </tr> <tr> <td><b>TOTAL:</b></td> <td>Min. 7 days</td> </tr> </table> <p><b>Programme 2 or 3:</b></p> <table border="1"> <tr> <td><b>Competition days:</b></td> <td>Min. 3 days</td> </tr> <tr> <td><b>Classification/ Equipment Control:</b></td> <td>2 days prior to competition</td> </tr> <tr> <td><b>TOTAL:</b></td> <td>Min. 5 days</td> </tr> </table>	<b>Competition days:</b>	Min. 5 days	<b>Classification / Equipment Control:</b>	2 days prior to <a href="#">competition</a> <a href="#">Competition</a>	<b>TOTAL:</b>	Min. 7 days	<b>Competition days:</b>	Min. 3 days	<b>Classification/ Equipment Control:</b>	2 days prior to competition	<b>TOTAL:</b>	Min. 5 days
	<b>Competition days:</b>	Min. 7 days																																						
<b>Classification/ Equipment Control:</b>	2 days prior to <a href="#">competition</a> <a href="#">Competition</a>																																							
<b>TOTAL:</b>	Min. 9 days																																							
<b>Competition days:</b>	Min. 8 days																																							
<b>*Classification/ Equipment Control:</b>	2 days prior to <a href="#">competition</a> <a href="#">Competition</a>																																							
<b>TOTAL:</b>	Min. 10 days																																							
<b>Competition days:</b>	Min. 5 days																																							
<b>Classification / Equipment Control:</b>	2 days prior to <a href="#">competition</a> <a href="#">Competition</a>																																							
<b>TOTAL:</b>	Min. 7 days																																							
<b>Competition days:</b>	Min. 3 days																																							
<b>Classification/ Equipment Control:</b>	2 days prior to competition																																							
<b>TOTAL:</b>	Min. 5 days																																							
<b>Competition days:</b>	Min. 5 days																																							
<b>Classification / Equipment Control:</b>	2 days prior to <a href="#">competition</a> <a href="#">Competition</a>																																							
<b>TOTAL:</b>	Min. 7 days																																							
<b>Competition days:</b>	Min. 3 days																																							
<b>Classification/ Equipment Control:</b>	2 days prior to competition																																							
<b>TOTAL:</b>	Min. 5 days																																							
<b>Time schedule</b>	Depending on <a href="#">the shooting range capacity</a> . <del>To</del> <a href="#">This must be approved by World Shooting Para Sport WSPS.</a>	<del>Depending on shooting range capacity. To be approved by World Shooting Para Sport.</del>	Depending on shooting range capacity. <del>To be approved by World Shooting Para Sport.</del>	Depending on shooting range capacity. <del>To be approved by World Shooting Para Sport.</del>																																				
<b>Results template</b>	<del>Managed</del> <a href="#">This must be managed by World Shooting Para Sport the WSPS Official Results Provider and sent to</a>	<del>Managed by World Shooting Para Sport Official Results Provider and sent to World Shooting Para Sport</del>	<del>Managed by World Shooting Para Sport Official Results Provider and sent to World Shooting Para Sport</del>	<del>Results</del> <a href="#">The results must be submitted with the WSPS template to World Shooting Para Sport Office WSPS office 7 days after</a> <a href="#">competition</a> <a href="#">Competition</a> or																																				

# APPENDIX Appendix 1

Requirements ~~and designation~~ & Designation of ~~competitions~~ Competitions

	<del>World Shooting Para Sport</del> WSPS			sooner.
<b>Result Book</b>	Coordinated and published by OCOG, with review and approval by TD.	As per <del>World Shooting Para Sport</del> the WSPS template. Coordinated by TD and RTS Jury Chairperson, <del>and published.</del> Published by <del>World Shooting Para Sport.</del> WSPS	<del>As per World Shooting Para Sport template. Coordinated by TD and RTS Jury Chairperson, and published by World Shooting Para Sport.</del>	Coordinated and published by <u>the</u> LOC, with review and approval by <u>the</u> TD.



## APPENDIX Appendix 2

Overview of Level 1 (Approved Recognised Competition) requirements- Requirements



## APPENDIX 2

### Overview of Level 1 (Approved Competition) requirements

#### 1—Sanctioning process

- 1.1—Application forms must be completed in full and submitted to World Shooting Para Sport Office at [ipcshooting@paralympic.org](mailto:ipcshooting@paralympic.org) no later than 6 months prior to the commencement of the competition.
- 1.2—Applications submitted outside the given timelines or not completed in full will not be accepted.
- 1.3—World Shooting Para Sport will announce its decision to approve the competition officially in writing.
- 1.4—If approved, a 100 EUR (ex. VAT) sanctioning fee must be submitted by the LOC to IPC account. The LOC will be invoiced by World Shooting Para Sport.
- 1.5—All approved competitions will appear in the World Shooting Para Sport Calendar.

#### 2—Minimum requirements

- 2.1—**Rules:** the competition will be held according to current ISSF and World Shooting Para Sport Rules.
- 2.2—**Programme of events:** refer to World Shooting Para Sport rule 1.2.2.1
- 2.3—**Time schedule:** the time schedule should be developed by the LOC taking into consideration the number of firing points, expected number of athletes per event, type of targets (e.g. paper or electronic). The schedule needs World Shooting Para Sport prior approval before publishing.
- 2.4—**No. of days for classification, training & equipment control:** two (2) days are required prior to the competition days.
- 2.5—**Equipment:** full set of gauges and instruments for both ISSF and World Shooting Para Sport equipment control must be provided (Note: if the LOC does not own World Shooting Para Sport equipment control gauges and instruments, please inform World Shooting Para Sport and the purchase or loan of such items can be arranged).
- 2.6—**Event viability:** athletes from a minimum of three (3) NPCs must be entered by the final entries deadline. Otherwise an event is not considered viable and will be cancelled.
- 2.7—**Entries:** the final entries list must be sent to World Shooting Para Sport office the day after the final entries deadline and not later than 4 weeks prior the start of the competition. The athlete's SDMS ID number, international sport class and sport class status (if available) must be included in this list.

APPENDIX

Appendix 2 (International Approved Recognised Competition Requirements)-2017 Edition

## APPENDIX Appendix 2

Overview of Level 1 (Approved/Recognised Competition) requirements



2.8 **Technical officials:** the competition must be officiated by recognised ISSF and World Shooting Para Sport Judges.

- Technical Delegate/Chief Judge (An ITO from outside the Host Country will be appointed by World Shooting Para Sport);
- International Judge (ITOs from outside the Host Country will be appointed by World Shooting Para Sport, the number of ITOs to be appointed is outlined in World Shooting Para Sport Technical Rules and Regulations Appendix 1);
- National Judges (to be selected by the LOC as per ISSF rules).

2.9 **Classification panel:** an International classification panel will consist of two (2) International Classifiers and will be appointed by World Shooting Para Sport. For protest opportunities 2 panels of two (2) International Classifiers each must be appointed as per the IPC Classification Code (total number of 4 classifiers).

### 1 Results: Programme of Events Examples

1.1 The Competition Programme of Events recognised by World Shooting Para Sport (WSPS) at the varying Competition levels are:

Programme	Events included	Accepted at Competition level(s)		
		Grand Prix, World Cup, RCH World Cup	WCH	PG
<b>Programme 1</b>	All Events <ul style="list-style-type: none"> <li>▪ R1-R9</li> <li>▪ P1-P4</li> </ul>	x	x	✓
<b>Programme 2</b>	All Events <ul style="list-style-type: none"> <li>▪ R1-R9</li> <li>▪ P1-P5</li> <li>▪ VIS-VIP</li> <li>▪ PT1-PT3</li> <li>▪ MTR1-MTR2</li> <li>▪ MTP</li> </ul>	x	✓	x
<b>Programme 3</b>	▪ Any combination of events from Programme 2 as approved by WSPS.	✓	x	x

1.2 The Programme of Events for IPC Games will be confirmed in the qualification guide for such Competitions.

## APPENDIX Appendix 2

Overview of Level 1 (Approved/Recognised Competition) requirements



## 2 Application

- 2.1 [Competition hosting expression of interest application forms for WSPS Championships \(WCH/RCH\), Sanctioned Competitions \(World Cup\) and Approved Competitions \(Grand Prix\) can be found on the WSPS website.](#)
- 2.2 [To apply to host a WSPS Recognised Competition, the LOC must submit the results from relevant application form by the applicable deadline:](#)

<a href="#">Recognised Competition</a>		<a href="#">Deadline for application submission (months prior to proposed Competition date)</a>
<a href="#">WSPS Championships</a>	<a href="#">World &amp; Regional Championships</a>	<a href="#">24 months</a>
<a href="#">WSPS Sanctioned Competitions</a>	<a href="#">World Cup</a>	<a href="#">12 months</a>
<a href="#">WSPS Approved Competitions</a>	<a href="#">Grand Prix</a>	<a href="#">6 months</a>

- 2.3 [All applications will be reviewed at the discretion of WSPS.](#)
- 2.4 [WSPS will confirm to the applicant in writing the result of the application.](#)
- 2.5 [For WSPS Championships and WSPS Sanctioned Competitions - if an application is successful, the LOC must agree to the terms and conditions of a hosting agreement, as required by WSPS.](#)

## 3 Competition Entries

- 3.1 [All athletes must first be entered by their respective NPCs or other organisation authorised by the NPC and accepted by WSPS, in order to participate in any WSPS Recognised Competition.](#)
- 3.2 [All entries from NPCs must be received by the deadlines as set out in the Competition information package. Close of entries is midnight CET on the date given.](#)
- 3.3 [‘First Entry by Number’ must include:](#)
- 3.3.1 [total number of athletes and Team Officials participating; and](#)
  - 3.3.2 [number of individual and team Event entries the NPC will submit.](#)
- 3.4 [‘Final Entry by Name’ must include:](#)

## APPENDIX Appendix 2

Overview of Level 1 (Approved/Recognised Competition) requirements- Requirements



- 3.4.1 full details of all events to World Shooting Para Sport athletes entered to compete in the Competition;
  - 3.4.2 confirmation of all individual and team Event entries, with names of all athletes;
  - 3.4.3 confirmation (name and details) of all Team Officials participating at the Competition; and
  - 3.4.4 all Competition booking details (as applicable) including accommodation, transport and firearms information.
- 3.5 The entry criteria shall be defined in electronic version the Competition general information package and/or qualification documentation for each Competition.
- 3.6 An Event will only be considered viable if the minimum viability criteria (as specified in the standardised World Shooting Para Sport Results Template no later than 7 days after the end Appendix 1) is met by the time of the competition. Results recognition will follow the IPC Processes for rankings and Technical Meeting and reflected as such on the start list.
- 3.7 WSPS reserves the right to cancel in advance any Events which are not viable by the first entry by number deadline.

## 4 Maximum Number of Entries

- 4.1 At each WSPS Recognised Competition, the maximum number of starts per Event will be calculated; this calculation is based upon range capacity and the Competition schedule.
- 4.2 The entries accepted at WSPS Recognised Competitions can be defined as:
- 2.104.2.1 'Full' participants are athletes eligible to progress to the Finals, and to obtain records lists and ranking; and
  - 4.2.2 'MQS-only' participants are athletes eligible to obtain qualification scores to be recognised for MQS, but cannot progress to the Event Finals or obtain direct quota allocation, records or rankings.
- 4.3 The limit of maximum number of entries per NPC per Competition type can be summarised as follows:

## APPENDIX Appendix 2

Overview of Level 1 (Approved/Recognised Competition) requirements



<u>Competition</u>		<u>Maximum number of entries</u>	
		<u>'Full' participants</u>	<u>'MQS only' participants</u>
<u>IPC Games and WSPS Championships</u>	<u>Paralympic Games</u>	<u>Defined in Qualification Criteria</u>	<u>Not applicable</u>
	<u>World Championship</u>	<u>*4 per NPC per Event + defined in qualification criteria</u>	<u>Not applicable</u>
	<u>Regional Championship</u>	<u>*4 per NPC per Event + defined in qualification criteria</u>	<u>Unlimited (pending capacity)</u>
<u>WSPS Sanctioned Competitions</u>	<u>World Cup</u>	<u>*4 per NPC per Event</u>	<u>Unlimited (pending capacity)</u>
	<u>Regional Games</u>	<u>Defined in qualification criteria</u>	<u>Not applicable</u>
<u>WSPS Approved Competition</u>	<u>Grand Prix</u>	<u>Unlimited</u>	<u>Unlimited (pending capacity)</u>

\*in accordance with rule 4.3.1 below.

- 4.3.1 NPCs may enter 4 athletes per Event if 1 athlete is a female or a junior, otherwise NPCs may only enter 3 athletes per Event.
- 4.3.2 When entering more than four athletes to an Event via the online entry system, the NPC must confirm which athletes are to be entered as "Full" entry and which as "MQS-only".
- 4.3.3 If the maximum number of starts is reached the number of 'MQS-only' entries may be limited; in such cases, affected NPCs will be notified by WSPS.

## 5 Entry Fees

### 5.1 Event entry fee (World Cup or Grand Prix Competitions only)

#### 5.1.1 Basic entry fee

APPENDIX

Appendix 2 (International Approved/Recognised Competition Requirements) 2017 Edition

## APPENDIX Appendix 2

Overview of Level 1 (Approved/Recognised Competition) requirements- Requirements



5.1.1.1 A basic entry fee shall be charged by the LOC to all participating athletes and Team Officials.

5.1.1.2 The basic entry fee is calculated by the LOC according to the approximate price per person for services during the relevant Competition. The Event entry fee shall be charged as follows (included in the LOC entry fee):

(a) Individual Events (including Mixed Team) (World Cup): EUR 15 per athlete entry per Event;

(b) Individual Events (including Mixed Team) (Grand Prix): EUR 10 per athlete entry per Event;

(c) Team Events (World Cup): EUR 25 per team entry per team Event.

5.1.2 The basic entry fee and Event entry fee will be collected by the LOC by the deadline given in the Competition information package. The LOC may charge an additional fee in addition to the WSPS fee.

5.1.3 The LOC must transfer the Event entry fees to WSPS no later than 30 days after the receiving the invoice from WSPS.

### 5.2 **Late entries**

5.2.1 Late entry requests (submitted after the final entry by name deadline) will only be considered if they are received by WSPS no later than three days before the official arrival day of the relevant Competition.

5.2.2 Late entry requests may be accepted at the discretion of the LOC and WSPS if it is deemed that such late entries can be accommodated (i.e. within the Competition schedule, sufficient time for processing firearms permits); a late entry fee of EUR 100 will be charged and retained by the LOC per additional start.

### 5.3 **Entry changes**

5.3.1 Replacement entries may be accepted in the same Event, due only to injury or medical reason, at the sole discretion of WSPS, in consultation with the LOC. NPCs requesting replacement entries must submit supporting documents to WSPS for approval. All replacement athletes must already be entered in the competition.

### 5.4 **Cancellations**

5.4.1 The cancellation dates and policies for each Competition will be published in each Competition information package and must be adhered to.

## APPENDIX Appendix 2

Overview of Level 1 (Approved/Recognised Competition) requirements- Requirements



5.4.2 Any teams cancelling any bookings or participants after the final cancellation deadline will be liable for all costs incurred.

## 6 Minimum Qualifying Scores (MQS)

6.1 All athletes will be required to reach set MQS to be eligible to compete in certain Competitions. The MQS will be defined by WSPS for each Events and published in the relevant qualification documentation for each Competition.

6.2 There is no required MQS for competing in a WSPS World Cup or Grand Prix.

## APPENDIX Appendix 3

Overview of Level 2 (World Cup and Grand Prix) requirements ~~Sanctioned & Approved Competition Requirements~~

### APPENDIX 3

## 1 Overview of ~~Level 2~~WSPS Sanctioned Competitions (World Cup and Grand Prix) requirements) Requirements

### 1.1 Sanctioning ~~Process~~process

~~1.1.1.1~~ Applications must be completed in full and submitted to ~~World Shooting Para Sport Office~~WSPS ~~office~~ office at ~~ipcshooting@paralympic.org~~info@worldshootingparasport.org no later than 12 months prior to the ~~competition~~Competition.

~~1.2.1.1.2~~ Applications submitted outside the given timelines or not completed in full may not be accepted.

~~1.3.1.1.3~~ If deemed necessary by ~~World Shooting Para Sport~~WSPS, prior to a sanctioning decision a site visit may be required to be conducted by ~~World Shooting Para Sport~~WSPS (at the LOC cost).

~~1.4~~ A maximum of four (4) Level 2 competitions will be sanctioned per year. Priority for sanctioning will be given to ~~World Cup~~ competitions.

~~1.4.1~~ World Shooting Para Sport

~~1.5~~ World Shooting Para Sport will announce its decision to approve the competition officially in writing.

~~1.1.4~~ WSPS will provide an LOC with its decision in writing whether or not to sanction the Competition (acting in its absolute discretion). ~~WSPS Sanctioned Competitions will only be officially announced after the LOC has entered into a hosting agreement with WSPS for the Competition, unless WSPS determines otherwise.~~

~~1.6.1.1.5~~ If the ~~competition~~Competition is ~~approved~~sanctioned, a sanctioning fee of EUR 200 must be paid by the LOC to ~~IPC~~WSPS (LOC will be invoiced accordingly).

~~• 200 EUR (excluding VAT);~~

~~1.7.1.1.6~~ All ~~sanctioned competitions~~WSPS Sanctioned Competitions will appear ~~in the World Shooting Para Sport Calendar~~on the WSPS calendar.

### 1.2 General requirements

~~2.1.1.2.1~~ Rules: ~~the competition will~~All WSPS Sanctioned Competitions must be held according to current ISSF and World Shooting Para Sport ~~in accordance with these Rules and Regulations.~~

~~2.2.1.2.2~~ Programme of ~~events~~Events:



## APPENDIX Appendix 3

### Overview of Level 2 (World Cup and Grand Prix) requirements – Sanctioned & Approved Competition Requirements

~~1.2.2.1~~ Refer to ~~World Shooting Para Sport rule 1.2.2.1~~ WSPS Regulation 2.1.1 for the Events which may be included in WSPS Sanctioned Competitions.

~~1.2.2.2~~ Finals are required for all ~~events~~ (Events except R9 & P5).

~~1.2.3~~ ~~No-Number~~ of days for classification, training & equipment control: ~~two~~

~~2.4~~ ~~Two~~ (2) days are required prior to the ~~competition~~ **Competition** days.

~~2.5~~ **Minimum days of competition days:**

- ~~▪~~ For Programme 1: Five (5) days
- ~~▪~~ For Programme 2: Three (3) days
- ~~▪~~ For Programme 3: Three (3) days

~~1.2.3.1~~ ~~Doping for Classification, training and Equipment Control: A, unless WSPS determines otherwise.~~

**1.2.4 Classification:**

~~1.2.4.1~~ International Classification must be held at all WSPS Sanctioned Competitions, unless WSPS determines otherwise.

~~1.2.4.2~~ Unless agreed otherwise by WSPS, an International Classification Panel will consist of at least two (2) International Classifiers per impairment group - Physical Impairment (PI) or Visual Impairment (VI) – who will be appointed by WSPS.

**1.2.5 Anti-Doping:**

~~1.2.5.1~~ Doping control must take place at all WSPS Sanctioned Competitions, unless specified otherwise by WSPS.

~~1.2.5.2~~ Prior to the Competition, the LOC must enter into a Doping Control Agreement (DCA) ~~will be signed between the LOC and IPC with WSPS, and/or other parties as required by WSPS, which shall set out the size and type of the testing programme to be conducted at the Competition, unless WSPS determines otherwise.~~

**1.3 Entries**

~~1.3.1.1~~ The ~~IPC Online~~ **WSPS online** entry system will be used for this ~~event~~ **Event** for athlete entries; other entry forms (i.e. ~~Team Official registration, Transport and Accommodation booking – if required~~) ~~should~~ **must** be distributed to teams along with the Competition ~~Information Package (World Shooting Para Sport information package (WSPS will send templates of these forms to the LOC if requested).~~

~~1.3.2~~ All ~~Athletes~~ **athletes** are required to ~~be licensed~~ **have a WSPS License** by the ~~Final Entry~~ **final entry** deadline.

## APPENDIX Appendix 3

### Overview of Level 2 (World Cup and Grand Prix) requirements Sanctioned & Approved Competition Requirements

3.3 Unless specified otherwise by WSPS, the estimated number of participants World Shooting Para Sport are:

World Cup	Grand Prix
Athletes: 100-180	Athletes: 80-120
Team Officials: 40-90	Team Officials: 30-60

3.3.1.3.3 Estimated number of wheelchair users World Shooting Para Sport at the Competition will be as follows:

- 1.3.3.1 WSPS Athletes = 50-60% of the total number of athletes
- 1.3.3.2 Team officials = 2-3% of the total number of team officials Team Officials

#### 3.4.1.4 Event viability

3.4.1.4.1 The minimum number of entries for per event Event are:

- 1.4.1.1 Individual events Events: four (4) athletes from four (4) NPCs;
- 1.4.1.2 Team events Events: teams from a minimum of three (3) NPCs.

3.4.2.1.4.2 If the minimum viability criteria is not met by the final entries deadline an event Event is not considered viable and will may be cancelled shot for MQS score only at the discretion of the Technical Delegate.

#### 3.5.1.4.3 Competition Information Package (CIP) information package

3.5.1.4.3.1 The Competition Information Package (CIP) information package and entry forms should must be sent to NPCs no later than 4 months prior to the competition start date. World Shooting Para Sport in a timely manner. WSPS will distribute the information package and forms to NPCs, and also publish the information on the website ([www.ipe-paralympic.org/shooting.org/events](http://www.ipe-paralympic.org/shooting.org/events)).

10

3.5.2.1.4.3.2 The CIP LOC's Competition information package must include all:

- a) deadlines Deadlines for entry applications;
- b) Financial financial matters including full costs (entries, accommodation, etc) and bank transfer details;
- c) Transportation transportation details including to/from airport and hotel;
- d) Accommodation accommodation details/options;
- e) Weapons weapons import and visa procedures; and
- f) Preliminary competition a preliminary Competition schedule.

## APPENDIX Appendix 3

### Overview of Level 2 (World Cup and Grand Prix) requirements Sanctioned & Approved Competition Requirements

~~3.5.31.4.3.3~~ A ~~CIP~~ template will be sent to the LOC by ~~World Shooting Para Sport~~ ~~WSPS~~, if requested. The ~~CIP~~ template ~~should~~ or other document ~~must~~ be completed by the LOC and sent to ~~World Shooting Para Sport~~ ~~WSPS~~ for approval, along with draft ~~competition~~ ~~Competition~~ schedule.

### 3.6 Fees

~~3.6.1~~ ~~Basic Entry Fee:~~ a Basic Entry Fee shall be charged by the LOC to all participating athletes and team officials. This fee should be calculated by the LOC according to the approximate price per person for services during the competition, and a proposal sent to World Shooting Para Sport for approval.  
**World Shooting Para Sport**

~~3.6.2~~ ~~Event Entry Fees:~~ in addition to the basic entry fee, the LOC will collect event entry fees of 10 EUR per athlete per individual entry and 20 EUR per team entry per event. These 'event entry fees' are to be paid to World Shooting Para Sport post-competition.

### 3.7 Deadlines:

#### 1.4.4 **Deadlines**

~~3.7.11.4.4.1~~ First ~~Entry~~ ~~entry~~ by ~~Number~~ ~~number~~: the ~~competition~~ ~~Competition~~ first entry by number deadline must be set to a minimum nine (9) of seven (7) weeks before the start of the ~~competition~~ ~~Competition~~;

~~3.7.21.4.4.2~~ Final ~~Entry~~ ~~entry~~ by ~~Name~~ ~~name~~: the ~~competition~~ ~~Competition~~ final entry deadline must be set to a minimum five (5) of three (3) weeks before the start of the ~~competition~~ ~~Competition~~.

~~3.81.4.4.3~~ ~~Bibs:~~ Following the final entry deadline ~~World Shooting Para Sport~~ ~~WSPS~~ will prepare ~~Athlete~~ ~~athlete~~, ~~loader~~ and ~~Leader Bibs~~ ~~assistant bibs~~ and ~~then~~ send to the LOC for printing and distribution.

### 1.5 Transport

~~4.11.5.1~~ Transport (airport to hotel, and hotel to venue) must be provided by LOC for all appointed ~~competition~~ ~~Competition~~ officials (~~Technical Officials~~ ~~Competition Jury~~, Classifiers, ~~Management Team~~ ~~WSPS Staff~~).

~~4.21.5.2~~ ~~If the~~ ~~The~~ LOC ~~will~~ ~~must~~ provide transport (airport to hotel and/or hotel to venue) ~~to~~ ~~Athletes~~ ~~or transportation options to all athletes~~ and Team Officials, and a suitable number of accessible vehicles must be provided.

## APPENDIX Appendix 3

### Overview of Level 2 (World Cup and Grand Prix) requirements – Sanctioned & Approved Competition Requirements

#### 1.6 Accommodation

~~5.11.6.1~~ If the LOC will offer accommodation services to ~~Athletes~~athletes and Team Officials ~~as part of the competition entry package~~, a suitable number of accessible rooms must be provided in accordance with local regulations.

~~1.6.1.1~~ For information about accessibility considerations, refer to the IPC Accessibility Guide.

#### 1.7 Venue

##### ~~1.7.1~~ General Venue requirements (firing

12

~~6.11.7.1.1~~ Firing points, ranges specifications, etc.) are as according to ~~the ISSF rules~~these Rules and Regulations.

##### ~~6.21.7.2~~ Equipment

~~6.2.11.7.2.1~~ Electronic ~~Targets~~targets are mandatory. Targets and results services must be provided by the ~~World Shooting Para Sport~~WSPS Official Results & Target System Provider (see LOC obligation details at [www.ipe-paralympic.org/shooting.org/organisers](http://www.ipe-paralympic.org/shooting.org/organisers));

~~6.2.21.7.2.2~~ FullThe full set of ~~gauges and instruments~~devices for both ~~the~~ ISSF and ~~World Shooting Para Sport~~WSPS equipment control must be provided ~~by~~ LOC (Note: if the LOC does not own ~~an World Shooting Para Sport~~a WSPS equipment control ~~gauges and instruments~~device, please inform ~~World Shooting Para Sport~~WSPS and the purchase or loan of such items can be arranged).

##### ~~6.31.7.3~~ Accessibility

~~6.3.11.7.3.1~~ The venue must be accessible to wheelchair users, including ‘barrier-free’ access to the venue and field of play.

~~6.3.21.7.3.2~~ A suitable number of accessible toilets must be available at the venue. ~~refer to the IPC Accessibility Guide.~~

##### ~~6.41.7.4~~ Information services:

~~6.4.11.7.4.1~~ A results board (for results display) must be provided ~~on~~at the venue. ~~refer to the IPC Accessibility Guide.~~

~~6.4.21.7.4.2~~ A website must be provided for distributing documents and notices to delegations and officials. ~~refer to the IPC Accessibility Guide.~~

~~6.4.31.7.4.3~~ An information desk or notice board for ~~competition~~Competition information ~~should~~must be ~~made~~ available to teams at the venue and official hotel (if applicable). ~~refer to the IPC Accessibility Guide.~~

## APPENDIX Appendix 3

### Overview of Level 2 (World Cup and Grand Prix) requirements Sanctioned & Approved Competition Requirements

~~6.4.4~~1.7.4.4 It is strongly recommended by World Shooting Para Sport that the The LOC must provide free Wi-Fi services to all officials and participants across the venue.

#### ~~6.5.1~~1.7.5 Meeting rooms and office facilities

~~6.5.1~~1.7.5.1 A large room or space must be allocated to be used for the Technical Meeting (there will be approximately 2 persons per participating country attending).

~~6.5.2~~1.7.5.2 An office for the Technical Delegate (WSPS Staff, and World Shooting Para Sport Manager, if attending), Competition Jury must be allocated provided. The allocated office must include access to internet, printer and photocopier.

#### ~~6.6.1~~1.7.6 Classification

~~6.6.1~~ For full requirements for Classification areas, please see the LOC Guidelines on the World Shooting Para Sport website: [www.ipc-shooting.org/organisers](http://www.ipc-shooting.org/organisers)

1.7.6.1 LOC must provide all necessary facilities to allow classification to be conducted in accordance with the WSPS Classification Rules and Regulations.

13

1.7.6.2 The LOC must comply with WSPS Classification requirements provided by WSPS.

## 1.8 Officials

~~7.11.8.1~~World Shooting Para Sport WSPS will appoint the necessary number of officials WSPS Officials, and confirm the names to the LOC in writing.

~~7.21.8.2~~ The LOC ~~should~~must budget to cover the following number of WSPS officials and relevant costs/services:

Role	Number of persons	Period of attendance	Services to be provided
Technical Delegate	1	<ul style="list-style-type: none"> <li>▪ Arrive: 2-3 days before <u>start of</u> <u>Equipment Control/Training</u> <u>the official arrival day</u></li> <li>▪ Depart: Day after <u>the end of</u> <u>competition</u> <u>the Competition</u></li> </ul>	<ul style="list-style-type: none"> <li>▪ Flights</li> <li>▪ Transport</li> <li>▪ Accommodation</li> <li>▪ Catering</li> </ul>

## APPENDIX Appendix 3

### Overview of Level 2 (World Cup and Grand Prix) requirements Sanctioned & Approved Competition Requirements

ITOs Competition Jury	3-8 (depending on the Competition programme)	<ul style="list-style-type: none"> <li>Arrive: 1 day before start of Equipment Control/Training the official arrival day</li> <li>Depart: Day after end the of competition the Competition</li> </ul>	<ul style="list-style-type: none"> <li>Flights</li> <li>Transport</li> <li>Accommodation</li> <li>Catering</li> </ul>
Chief Classifier	1	<ul style="list-style-type: none"> <li>Arrive: 2 days before start of Classification the official arrival day</li> <li>Depart: Day 3 days after the end of classification Classification</li> </ul>	<ul style="list-style-type: none"> <li>Flights</li> <li>Transport</li> <li>Accommodation</li> <li>Catering</li> </ul>
Classifiers	1-3 (depending on decision by WSPS of no. of classification panels Classification Panels to be provided)	<ul style="list-style-type: none"> <li>Arrive: 1 day before start of Classification the official arrival day</li> <li>Depart: Day after the end of classification Classification</li> </ul>	<ul style="list-style-type: none"> <li>Flights</li> <li>Transport</li> <li>Accommodation</li> <li>Catering</li> </ul>
WSPS Sport Manager Staff	1	<ul style="list-style-type: none"> <li>Arrive: 1 day before start of Equipment Control/Training the official arrival day</li> <li>Depart: Day after the end of competition the Competition</li> </ul>	<ul style="list-style-type: none"> <li>Flights</li> <li>Transport</li> <li>Accommodation</li> <li>Catering</li> </ul>

## APPENDIX Appendix 3

### Overview of Level 2 (World Cup and Grand Prix) requirements – Sanctioned & Approved Competition Requirements

#### 1.8.3 National technical officials

1.8.3.1 An appropriate number of national technical officials are to be selected and appointed by the LOC in consultation with WSPS.

#### 7.31.8.4 Competition Juries

7.3.1.8.4.1 World Shooting Para Sport WSPS will provide a list of Competition Jury appointments to the LOC following the official appointment process by World Shooting Para Sport WSPS.

7.3.21.8.4.2 One member per Competition Jury is to be provided by the LOC.

7.4 National Technical Officials: an appropriate number (calculated as per ISSF Rules) are to be selected and appointed by the LOC.

#### Protocol

#### 8.11.8.5 Medals

8.1.11.8.5.1 The LOC must send the proposed medal designs to World Shooting Para Sport WSPS for approval.

8.1.21.8.5.2 Medal design must follow the World Shooting Para Sport WSPS brand guidelines and include:

- a) Front: Event Competition logo & official event title Competition name
- b) Back: World Shooting Para Sport WSPS wordmark
- c) Ribbon: plain or a design chosen by LOC (to be approved by World Shooting Para Sport WSPS).

14

#### 8.21.8.6 Victory Ceremonies

8.2.11.8.6.1 Depending on the preference of the LOC, victory ceremonies can be scheduled following each final Finals or at the end of every day.

8.2.21.8.6.2 The Victory Ceremony victory ceremony area must be accessible for wheelchair users.

8.2.31.8.6.3 A back-drop and podium must be prepared by LOC for the ceremonies, and the designs must be sent to World Shooting Para Sport WSPS for approval.

8.2.41.8.6.4 The LOC must provide the national anthems and the three (3) flags of each participating NPC of the same size (NOTE: total number of required flags per NPC can be finalised with World Shooting Para Sport WSPS following the final entry deadline).



## APPENDIX Appendix 3

### Overview of Level 2 (World Cup and Grand Prix) requirements – Sanctioned & Approved Competition Requirements

#### ~~8.3.1.8.7~~ **Opening and Closing Ceremonies**closing ceremonies

~~8.3.11.8.7.1~~ Opening and Closing Ceremoniesclosing ceremonies are optional.

~~8.3.21.8.7.2~~ If an LOC wishes to plan an Openingopening and/or Closing Ceremonyclosing ceremony, plans must be approved by World Shooting Para SportWSPS.

### 1.9 Branding

~~9.11.9.1~~ Any competitionCompetition branding (including posters, banners, brochures, etc) must include the official eventCompetition title and eventCompetition logo World Shooting Para Sportas determined and provided to the LOC by WSPS.

1.9.2 A design of all planned materials must be sent in good time to World Shooting Para Sportto WSPS for approval.

### 1.10 Broadcasting / Live Stream

1.10.1 A live stream must be provided to WSPS for the Finals of all Events.

1.10.2 LOCs must contact WSPS for the broadcast/live stream requirements.

## 2 WSPS Approved Competition (Grand Prix) Requirements

### 2.1 Approval process

15

2.1.1 Application forms for WSPS Approved Competitions must be completed in full and submitted to the WSPS office at [info@worldshootingparasport.org](mailto:info@worldshootingparasport.org) no later than six (6) months prior to the commencement of an WSPS Approved Competition.

2.1.2 Applications submitted outside the given timelines or not completed in full will not be accepted by WSPS.

2.1.3 WSPS will provide an LOC with its decision in writing whether or not to approve the Competition (acting in its absolute discretion).

2.1.4 If approved, a EUR 100 approval fee must be transferred by the LOC to WSPS's nominated account as invoiced by WSPS.

2.1.5 All WSPS Approved Competitions will appear in the WSPS calendar.

### 2.2 Minimum Requirements

2.2.1 **Rules:** all WSPS Approved Competitions must be held according to these Rules and Regulations.

2.2.2 **Programme of Events:** Refer to WSPS Regulation 2.1.1 for the Events which may be included in WSPS Approved Competitions.



## APPENDIX Appendix 3

### Overview of Level 2 (World Cup and Grand Prix) requirements - Sanctioned & Approved Competition Requirements

- 2.2.3 Time schedule:** the time schedule must be developed by the LOC taking into consideration the number of firing points, expected number of athletes per Event, type of targets (e.g. paper or electronic). The LOC must obtain WSPS's approval of the schedule before publishing.
- 2.2.4 Number of days for classification, unofficial training & equipment control:** two (2) days are required prior to the competition days.
- 2.2.5 Equipment:** full set of devices for both the ISSF and WSPS Equipment Control must be provided by LOC. (Note: if the LOC does not own WSPS equipment control devices, please inform WSPS and the purchase or loan of such items can be arranged).
- 2.2.6 Entries:** the final entries list must be sent to WSPS office after the final entries deadline and not later than 4 weeks prior the start of the Competition. The athlete's WSPS License number, international Sport Class and Sport Class Status (if available) must be included in this list.
- 2.2.7 Number of wheelchair users:** The estimated number of wheelchair users at the Competition will be as follows:
- 2.2.7.1 WSPS Athletes = 50-60% of the total number of athletes.
  - 2.2.7.2 Team officials = 2-3% of the total number of Team Officials.
- 2.2.8 Officials**
- 2.2.8.1 Technical Delegate: a Technical Delegate will be appointed by WSPS.
  - 2.2.8.2 Competition Jury: the Competition must be officiated by a WSPS Competition Jury, to be appointed by WSPS. The number of Competition Jury members to be appointed is outlined in Appendix 1.
  - 2.2.8.3 National Judges: National judges are to be selected by the LOC and confirmed by WSPS.
- 2.2.9 Classification (optional):** Unless agreed otherwise by WSPS, an International Classification Panel will consist of at least two (2) certified International Classifiers per impairment group - Physical Impairment (PI) or Visual Impairment (VI) - to be appointed by WSPS.
- 2.2.2.10 Results:** the LOC must submit the results from all Events to WSPS in electronic format in the standardised WSPS results template no later than seven (7) days after the end of the Competition. Results recognition will follow the WSPS processes for MQS scores.

[APPENDIX Appendix 4](#)

Bib [templates Templates](#)



[APPENDIX Appendix 4](#)

Bib [templates Templates](#)

[3.1 Athlete Bib Template](#)



[WSPS Partners Logo](#)

[LOC Sponsors](#)

[3.2](#)

Loader or Assistant Bib Template



[WSPS Partners Logo](#)

[LOC Sponsors](#)

# Appendix 5: World Shooting Para Sport (WSPS) Equipment Control Sheet



<b>Competition</b>	
--------------------	--

Last Name	First Name	Gender	Classification	NPC	Athlete ID #	Start #
		Male / Female	_____			

**PART A**

**PART B**

**PART C**

<b>Athlete to Complete:</b>		
<b>Participating Event:</b>		
<i>(a) tick to indicate your Participating Event(s)</i>		
<b>Rifle</b>		
<i>[Tick]</i>	<b>Code</b>	<b>Event name</b>
	R1	Men's 10m Air Rifle Standing SH1
	R2	Women's 10m Air Rifle Standing SH1
	R3	Mixed 10m Air Rifle Prone SH1
	R4	Mixed 10m Air Rifle Standing SH2
	R5	Mixed 10m Air Rifle Prone SH2
	R6	Mixed 50m Rifle Prone SH1
	R7	Men's 50m Rifle 3 Positions SH1
	R8	Women's 50m Rifle 3 Positions SH1
	R9	Mixed 50m Rifle Prone SH2
	R10	Mixed Team SH1
	R11	Mixed team SH2
	VIS	Mixed 10m Rifle Standing
	VIP	Mixed 10m Rifle Prone
<b>Para-Trap</b>		
	PT1	Mixed Trap Seated SG-L
	PT2	Mixed Trap Standng SG- L
	PT3	Mixed Trap Standing SG-U
<b>Pistol</b>		
<i>[Tick]</i>	<b>Code</b>	<b>Event name</b>
	P1	Men's 10m Air Pistol SH1
	P2	Women's 10m Air Pistol SH1
	P3	Mixed 25m Pistol SH1
	P4	Mixed 50m Pistol SH1
	P5	Mixed 10m Air Pistol Standard SH1
	P6	Mixed team

<b>ISSF OR WSPS Judge to Complete:</b>				
<b>Athlete Firearm(s):</b>				
<b>Type</b>	<b>Manufacturer</b>	<b>Weight</b>	<b>Serial No.</b>	
Rifle   Pistol				
Rifle   Pistol				
Rifle   Pistol				
Rifle   Pistol				
Aiming Device		x		
LED Target		x		
Headphone		x		
<b>ISSF Firearms &amp; Equipment</b>				
<b>Rifle</b>				Check / Sign
Standards for all Rifles				
Rifle Visor or cap including Front Blinders				
<b>Pistol</b>				Check / Sign
Standards for all Pistols				
Shooting gear, including Front Blinders				
<b>Apparel</b>				Check / Sign
Jacket <i>(use separate form for measurements)</i>				
Trousers <i>(use separate form for measurements)</i>				
Footwear				
Gloves				
Kneeling roll				
<b>Para Trap</b>				Check / Sign
Vest				
Cap				
Glasses				
Side Blinder 60mm				
Butt Stock 170mm				
Strapping 10cm max				

<b>WSPS JUDGE (ONLY) to Complete:</b>	
<b>WSPS -Specific Equipment</b>	
<b>Miscellaneous</b>	Check / Sign
Compensating block	
Trigger extension/adaption	
Strapping	
Prosthesis	
Loading Device (Pistol)	
<b>Tables</b>	Check / Sign
Size	
Shape	
Form	
Angle	
Upholstering	
10cm block/table (kneeling support)	
<b>VI Equipment</b>	Check / Sign
Chair Without Back rest	
Prone table	
Opaque Glasses	
<b>Chairs</b>	Check / Sign
Shooting chair / High stool	
Side posts and armrests	
Backrest	
Visible Free Height	
Backrest slack	
<b>SH2 Support Stand</b>	Check / Sign
Yoke (rifle holder)	
Point of balance	
Spring flexibility	

<b>Athlete Signature</b>	<b>Date</b>
<b>Remarks (if required):</b>	

<b>ISSF Judge Signature</b>	<b>Date</b>
<b>Remarks (if required):</b>	

<b>WSPS Judge Signature</b>	<b>Date</b>
<b>Remarks (if required):</b>	

## APPENDIX Appendix 6

Trigger ~~extensions and adaptations~~ [Extensions & Adaptions](#)



## APPENDIX Appendix 6

Trigger ~~extensions and adaptations~~ [Extensions & Adaptions](#)

In accordance with the ISSF Rules, the style/shape of a trigger is a personal choice as long as it stays within the boundary of the given dimensions (as stated in ISSF [Rule Rules \(currently 7.4.4.1-Item D\)](#) 'Depth of fore-end' and Item I 'Maximum thickness (breadth) of the fore-end'). No definition of the shape of the trigger is given.

- **Trigger extension:** triggers that have modifications compared to standard triggers, but are inside the dimensions of ISSF [Rule 7.4.4.1 Rules](#) and protected by a trigger guard.
- **Trigger ~~Adaptions~~ adaptations:** triggers that have modifications compared to standard triggers, and are outside of the trigger guard and dimensions of ISSF [rule 7.4.4.1 Rules](#).
  - athletes must have a medical reason to use a trigger adaption;
  - this must be reviewed and approved by a World Shooting Para Sport Classification Panel during a [Technical Assessment technical assessment](#) (in consultation with the Technical Delegate, regarding the safe use of the proposed trigger adaptation) and recorded on the athlete's Classification and [WSPS License Cards](#).

To help to understand the differences, on the following pages are some example photographs and explanations.

## APPENDIX Appendix 6

Trigger ~~extensions and adaptions~~ [Extensions & Adaptions](#)



**Trigger extension:** trigger is inside the dimensions of ISSF [Rule 7.4.4.1 Rules](#) and protected by a trigger guard.



**Trigger extension:** trigger is inside the dimensions of ISSF [Rule 7.4.4.1 Rules](#) and protected by a trigger guard.

**Trigger extension:** trigger is inside the dimensions of ISSF [Rule 7.4.4.1 Rules](#) and protected by a trigger guard.



**Trigger adaptation:** trigger is outside the trigger guard and outside the dimensions of ISSF [rule 7.4.4.1 Rules](#).



## APPENDIX Appendix 6

Trigger ~~extensions and adaptations~~ Extensions & Adaptions



**Trigger adaptation:** trigger is outside the trigger guard and outside the dimensions of ISSF [rule 7.4.4.1 Rules](#).



**Trigger adaptation:** there is no trigger guard.



**Trigger adaptation:** trigger is outside the trigger guard and outside the dimensions of ISSF [rule 7.4.4.1 Rules](#)

## APPENDIX Appendix 6

Trigger ~~extensions and adaptations~~ [Extensions & Adaptions](#)



**Trigger adaptation:** trigger is outside the trigger guard and outside the dimensions of ISSF [rule 7.4.4.1 Rules.](#)



# APPENDIX Appendix 7

SH2 Support Stand & Springs  
Parts Drawings



# APPENDIX Appendix 7

SH2 Support Stand & Springs  
Parts Drawings

Updated [April 2016](#) [September 2020](#)

## 1 Overview

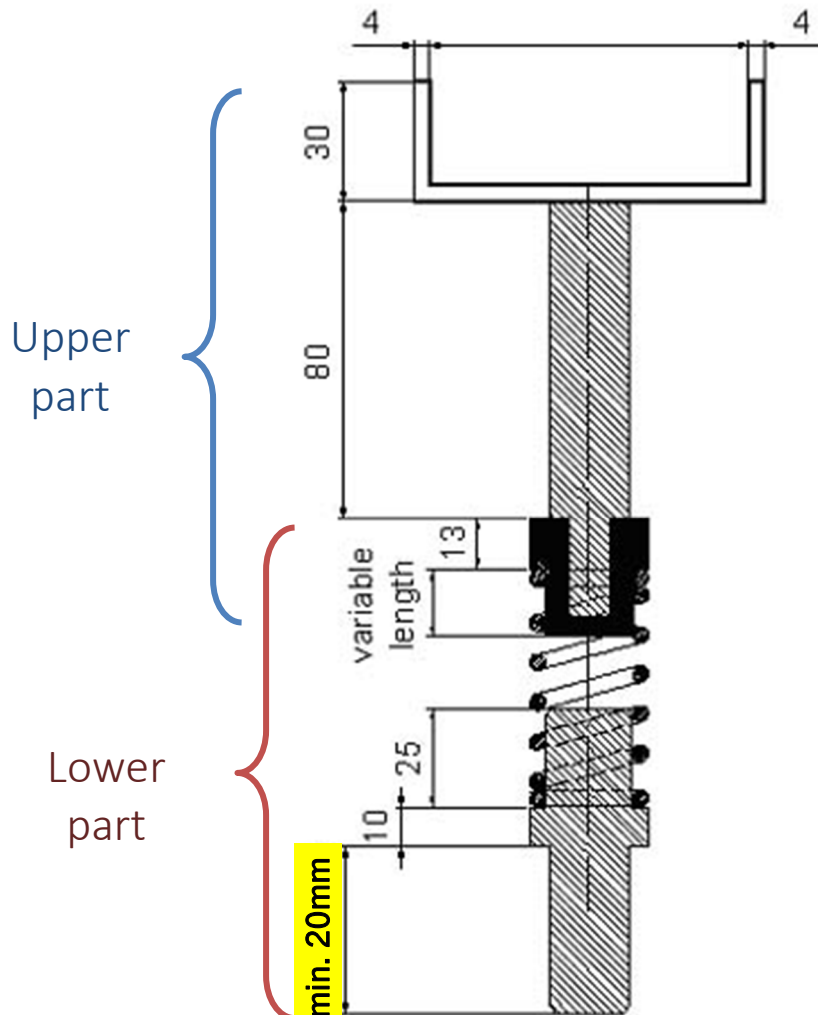

## 2 Upper part support (U form Shaft)

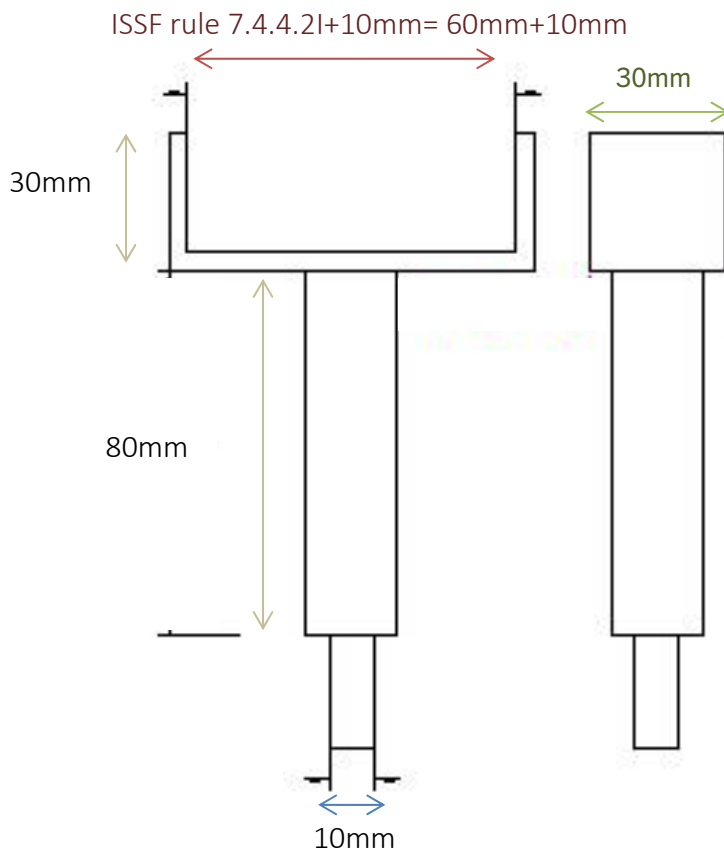

Max. weight: 200 grams

### 3 Support stand measuring procedure (Rule 2.9.13)

#### 3.1 Zero point

250 gram measuring bar is used to determine the zero point.

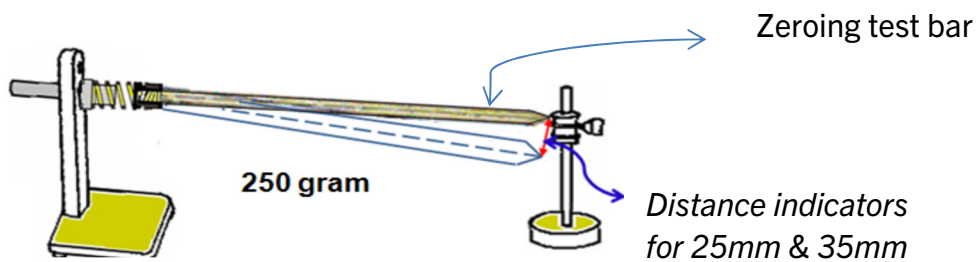

#### 3.2 Spring flexibility

720 gram measuring bar is used to indicate spring flexibility:

- Weak (a) spring: minimum 35mm flexibility
- Strong (b) spring: minimum 25mm flexibility

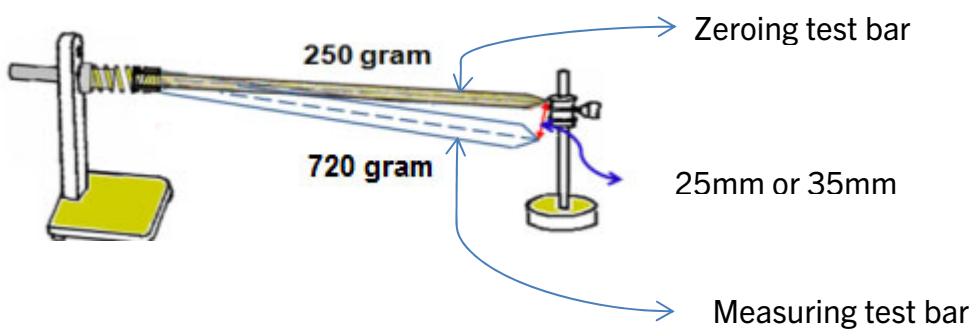

#### 4 Test Bar for Spring Flexibility (Rule 3.9.13)

- 4.1 All springs are checked and marked at the Equipment Control the following way. Any spring shall be tested in all four positions.
- 4.2 The spring is tested with the open turn to the top. If it passes the test, the spring will be marked with an Equipment Control sticker at the top. Checks will be more efficient this way and equal for all athletes.
- 4.3 If the spring fails the test, it will be retested up to 3 times at different positions by turning it 90 degrees' clockwise from the open turn. As soon as the spring passes the test, the spring will be marked with a sticker at the failing position opposite of the passing side; additionally, the sticker and the post will be marked with a thick red line.
- 4.4 All springs have to be used during the competition with the sticker (and possibly the red line) facing the athlete, so that the equipment control sticker is clearly visible to the range staff.

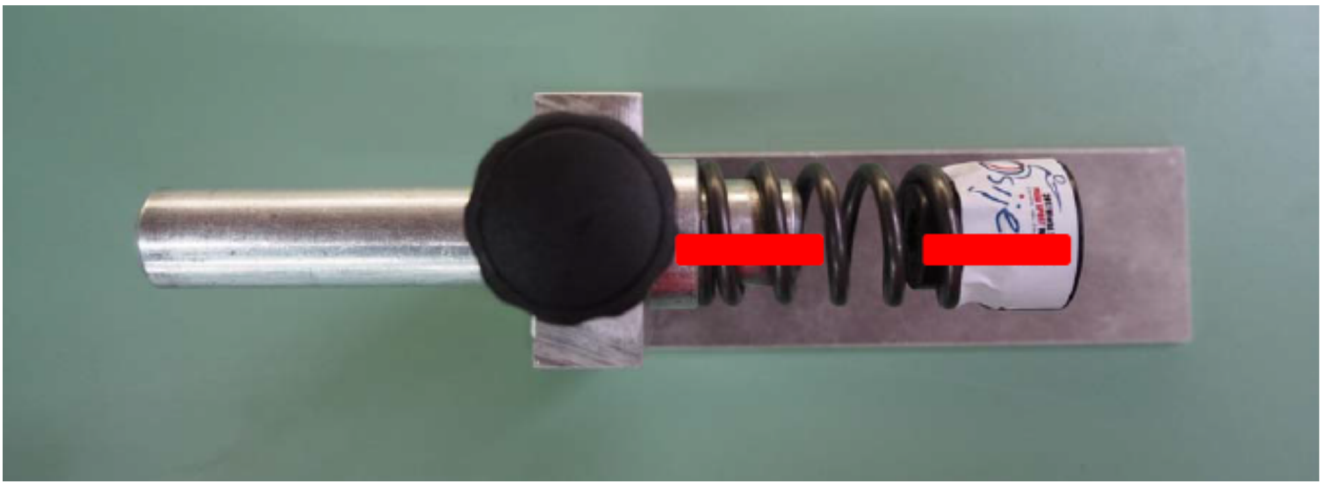

[5 SH2 Arrow Sticker](#)

# SH2 Arrow Sticker size

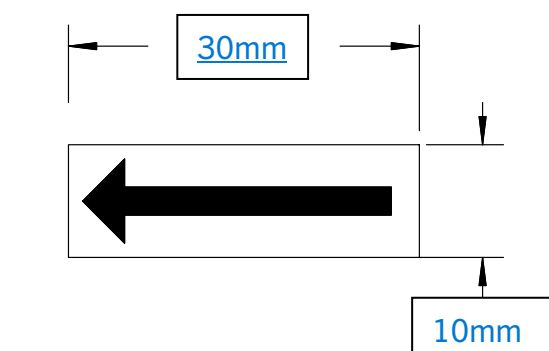

**APPENDIX Appendix 8**

**P5 10m Air Pistol Standard**

**1 General**

- 1.1 Any calibre 4.5 mm (.177) compressed air or gas pistol may be used.
- 1.2 The pistol used in the 10m five shot air pistol [eventEvent](#) must have a magazine that can be loaded with five (5) pellets.

**2 Competition**

- 2.1 Three (3) minutes preparation time will be given.
- 2.2 Ready position:
  - 2.2.1 Before each series the athlete must lower his arm. The pistol may be rested on the bench or shooting table.
  - 2.2.2 The pistol may not be raised or lifted to point towards the target until the command "START".
- 2.3 A series is considered as having started from the moment of the command "ATTENTION". Every shot fired after that will be counted in the [competitionCompetition](#).
- 2.4 Before the beginning of each [competitionCompetition](#) series, the athlete may fire one (1) sighting series of five (5) shots in ten (10) seconds.
- 2.5 All shooting (sighting and [competitionCompetition](#) series) [isare](#) by command. All athletes in the same range section must fire at the same time, but [organisersLOCs](#) may arrange for more than one range section to fire simultaneously under centralized commands.
- 2.6 The event is forty (40) [competitionCompetition](#) shots.
- 2.7 The [eventEvent](#) is divided into series of five (5) shots each in ten (10) seconds. In each series five shots are fired on one (1) Stationary Air Pistol target (see ISSF [RuleRules \(currently 6.3.2.6\)\)](#)) in the time limit for the series.

## 2.8 Commands

2.8.1 When the range officer gives the command “LOAD”, the athletes must prepare themselves for their series within one (1) minute.

2.8.2 When one (1) minute has expired, the ~~Range Officer~~[range officer](#) will give the commands:

"ATTENTION"
Seven (7) seconds after “ATTENTION”
"START" (the signal to fire).
After 10 seconds "STOP".
Shot(s) after the command "STOP" must be counted as zero(es) (0).

2.8.3 The timing will be controlled by stop watches.

2.8.4 Incorrect ~~Range Commands~~[range commands](#)

2.8.4.1 If the athlete wishes to protest because of an incorrect command and/or action by the range officer, the athlete must hold the pistol (or secure in the [Loading Device](#)~~loading device~~) pointing down range and raise their hand, and immediately after the series report this to the range officer or [jury](#) ~~Competition~~ [Jury](#) member.

2.8.4.2 If the claim is considered justified, the athlete must be allowed to fire the series.

2.8.4.3 If the claim is considered not justified, the athlete may fire the series, but must be penalized by the deduction of two (2) points in the event from the score of that series.

2.8.4.4 If the athlete has fired a shot after the incorrect command and/or action, the protest must not be accepted.

## 2.9 Scoring

2.9.1 All shots fired in the 10 seconds shooting time will be scored. Early and late shot(s) will be scored as zero(es).

2.9.2 Ties

- ~~2.9.2.1~~ Any ties for the first three (3) places will be resolved by shoot-off. This will compose of one sighting series in 10 seconds of 5 shots, followed by 1 series of 10 seconds of 5 shots, until the tie is broken.
- ~~2.9.2.2~~ Ties for fourth place and below, will be resolved by count-back in 5-shot-series. If any ties remain the athletes must have the same ranking.
- 2.9.2.1 Any ties will be broken by ISSF Rules (currently 6.15.1).

### 2.10 Interruption

- 2.10.1 If the interruption is for safety or technical reasons without fault of the athlete:
- 2.10.1.1 If the elapsed time is more than fifteen (15) minutes, the [Competition Jury](#) must allow one extra sighting series of five (5) shots.
- 2.10.1.2 [In the](#) 10m Air Pistol Standard Event, the interrupted series must be annulled and repeated. The repeated series must be recorded and credited to the athlete.
- 2.10.1.3 Any extension of time allowed by the [Competition Jury](#) or [Range Officers](#) [range officers](#) must be marked clearly, stating the reason, on the [Register Keeper's](#) [register keeper's](#) score card and on the scoreboard where it is visible clearly to the athlete.

### 2.11 Disturbances

- 2.11.1 Should an athlete consider that they were disturbed while firing a shot, the athlete must hold their pistol pointing down range (or secure in the [Loading Device](#) [loading device](#)) and inform immediately the [Range Officer](#) [range officer](#) or [Competition Jury Member](#) by raising their hand. The athlete must not disturb other athletes.
- 2.11.2 If the claim is considered justified:
- 2.11.2.1 The series must be annulled and the athlete may repeat the series.
- 2.11.3 If the claim is considered not justified:
- 2.11.3.1 If the athlete has finished his series, the shot or series must be credited to the athlete.
- 2.11.3.2 If the athlete has not finished his series due to the claimed disturbance, the athlete may repeat the series.



2.11.4 Scoring and penalties are as follows:

- 2.11.4.1 The score must be recorded as the total of the five (5) lowest value hits on the targets.
- 2.11.4.2 Two (2) points must also be deducted from the score of the repeated series.
- 2.11.4.3 In any repeated series, all five (5) shots must be fired at the target. Any shot(s) not fired or not hitting the target must be scored as zero(es).

## 2.12 Malfunctions

- 2.12.1 If a shot has not been fired due to a ~~malfunction~~**Malfunction**, and if the athlete wishes to claim a ~~malfunction, he~~**Malfunction, they** must ~~hold his~~**aim the** pistol pointing down range, retain his grip, and immediately inform the range officer by raising ~~his~~**their** free hand. ~~He~~**They** must not disturb other athletes.
  - 2.12.1.1 An athlete may try to correct a ~~malfunction~~**Malfunction** and continue the series, but after attempting any correction, ~~he~~**they** may not claim an **ALLOWABLE MALFUNCTION**~~allowable Malfunction~~ unless a part of the pistol is damaged sufficiently to prevent the pistol from functioning.
  - 2.12.1.2 If a ~~malfunction~~**Malfunction** occurs in the sighting series it must not be registered as a ~~malfunction. The sighting series may be completed (see ISSF rule 8.9.3c).~~**Malfunction.**
  - 2.12.1.3 The number of shots already fired must be recorded and the series may be repeated.
  - 2.12.1.4 Repeating a series because of a ~~malfunction~~**Malfunction** must be permitted <sup>29</sup> only in case of an **ALLOWABLE MALFUNCTION**~~and only once in a complete 40 shot event~~**allowable Malfunction.**
- 2.12.2 Scoring: **ALLOWABLE MALFUNCTION**~~allowable Malfunction~~
  - 2.12.2.1 The score must be recorded as the total of the five (5) lowest value hits on the targets. The athlete must fire all five (5) shots at the target in the repeat series. Any shot(s) not fired or not hitting the target in the re-shoot must be recorded as zero(es). ~~(Paper target~~**(If paper targets are** used, a second target must be provided for the re-shoot.)
- 2.12.3 Scoring: **NON ALLOWABLE MALFUNCTION**~~non allowable Malfunction~~

2.12.3.1 The score must be the total of the fired shots.

### 3 Other Specifications

Number of sighting shots	One (1) series of five (5) shots in ten (10) seconds
Targets	<a href="#">See According to ISSF Rule Rules (currently 6.3.2.6)</a>
Scoring	After every five (5) shot series
Competition shots	Eight (8) series of five (5) shots <span style="float: right;">30</span>
Competition time	10 seconds per shot series
Preparation time	Three (3) minutes
Maximum Pistol Weight	1500g
Minimum Trigger Pull	500g
Maximum Barrel Length - Sight Radius	Box Size Only 420mm x 200mm x 50mm
Grips	<ul style="list-style-type: none"> <li>▪ No part of the grip or accessories may encircle the hand. The heel rest must extend at an angle of not less than 90 degrees to the grip. Any upward curvature of the heel and/or thumb rest and/or a downward curvature of the side opposite the thumb is prohibited. The thumb support must allow free upward movement of the thumb. However, curved surfaces on the grips or frame, including the heel and/or thumb rest in the longitudinal direction of the pistol are permitted.</li> </ul>
Other specifications	<ul style="list-style-type: none"> <li>▪ Magazine loaded with five (5) pellets.</li> <li>▪ Ported barrels and perforated barrel attachments are allowed</li> <li>▪ The weighing of the pistol is made with all accessories, including balancing weights and unloaded magazine.</li> <li>▪ A manufacturing tolerance of the rectangular Measuring Box of 0.0mm to +1.0mm will be permitted. It may be measured with the magazine removed.</li> </ul>

## APPENDIX 10 Appendix 9

### Athlete Epilepsy Declaration

To be completed by all athletes and uploaded to the Athlete's SDMS profile by 01 February for each season.

<b>NPC</b>	
<b>SDMS ID No.</b>	
<b>Last Name</b>	
<b>First Name</b>	

Please check the appropriate statement:

<input type="checkbox"/>	I hereby declare that I have not been medically diagnosed with any form of epilepsy.
<input type="checkbox"/>	<p>I hereby declare that I have been medically diagnosed with epilepsy, but my condition is stable and I am free of any epileptic fit/seizure or epilepsy-related episode over the period of the last 12 months.</p> <p><i>Please state type of epilepsy you have been diagnosed with:</i></p>
<input type="checkbox"/>	<p>I hereby declare that I have been medically diagnosed with epilepsy, and that have suffered an epileptic fit/seizure or epilepsy-related episode over the period of the last 12 months.</p> <p><i>Please state type of epilepsy you have been diagnosed with, and date and details of the epileptic fit/seizure or epilepsy-related episode:</i></p>

<b>Athlete signature</b>	
<b>NPC Representative signature</b>	
<b>NPC Stamp</b>	
<b>Date</b>	

## 1 Aiming Device Requirements

### 1.1 Approved Suppliers

1.1.1 The following are approved suppliers for WSPS VI competitions:

EKO-AIMS type: VIS500 1.1

VIASS type: VIASS PRO artikel nr 10034

## 2 LED Requirements

### 2.1 LED Measurement

2.1.1 There must be a 5 mm IR LED with minimum wavelength range between 850 till 920 nm at an output level of > 50% radiation power (see picture below)

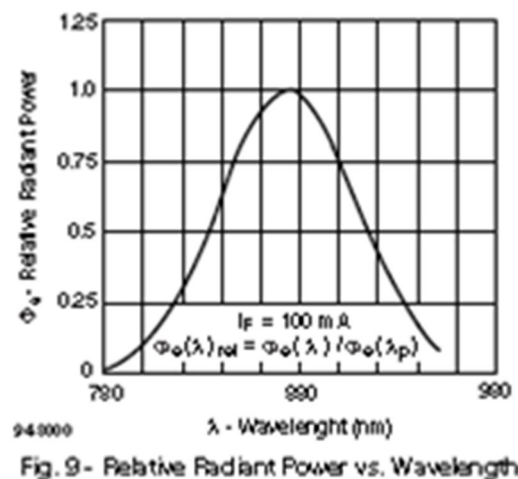

2.2 LED Position

2.3 The infrared (IR) Light Emitting Diode (LED) must be 60 mm right below the Rifle target centre.

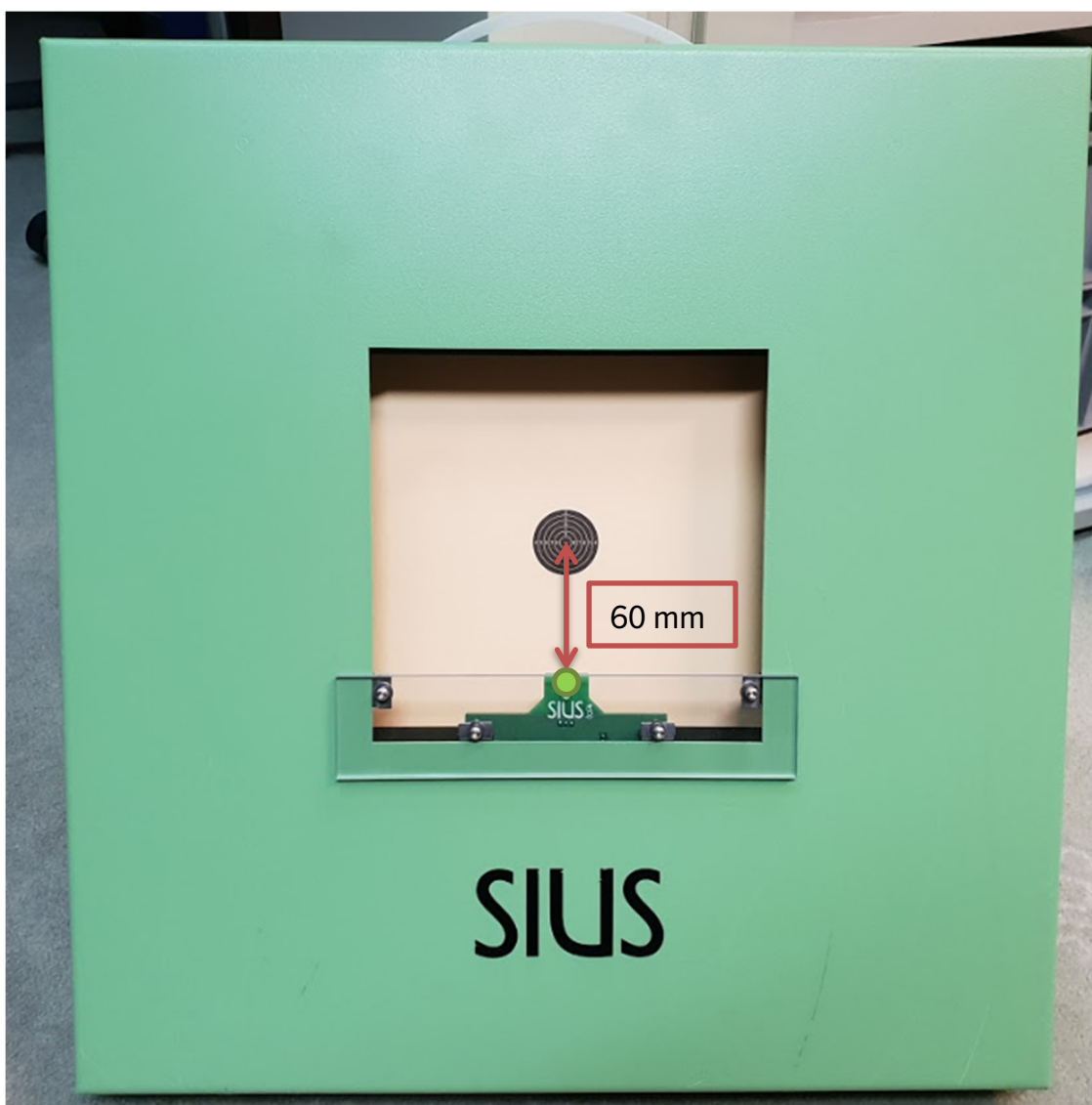

*SIUS dedicated IR unit for type LS10 or HS10 is powered by the system.*

- 2.3.1 The IR LED is above the green LED. The green LED must be on so [the Competition Jury members](#) can see if the IR LED is in function.

2.4 LED Insert

- 2.4.1 The IR LED is a device that can be attached to the front of the electronic target frame.
- 2.4.2 It can be a universal type or a dedicated type provide by the electronic target manufacturer.
- 2.4.3 Powering of the IR LED is done via direct connection to the electronic target or by a separate USB power source.

35

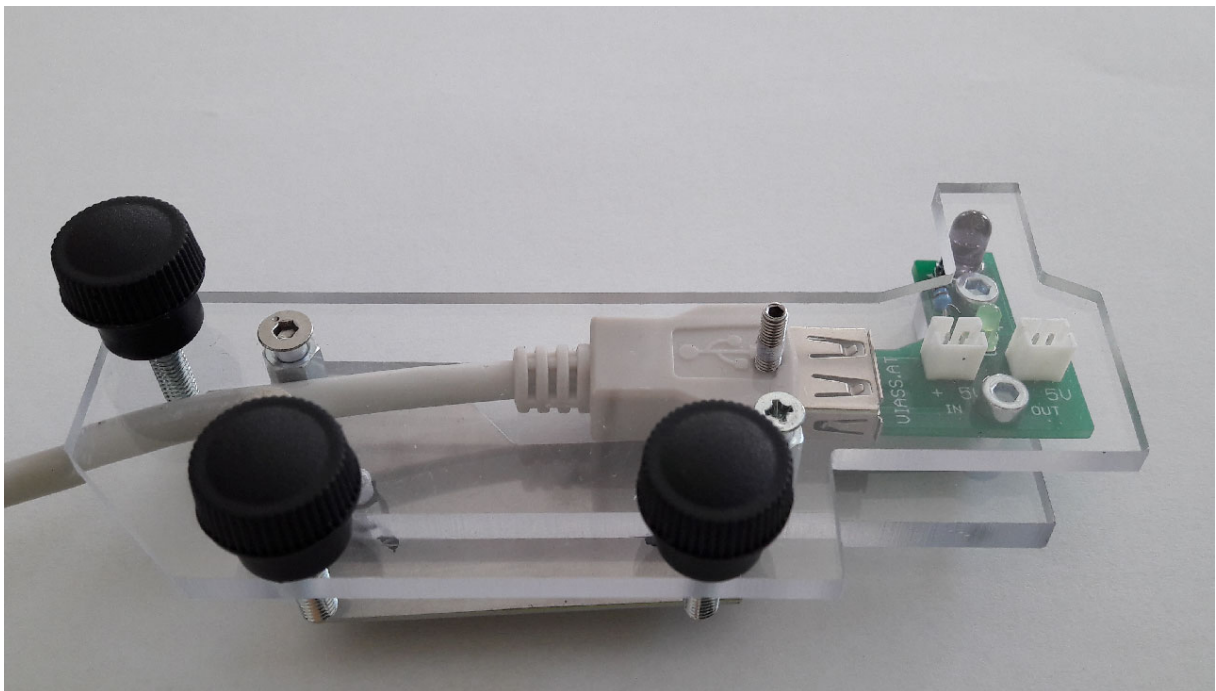

*This one fits for every electronic target*

- 2.4.4 The universal IR devices are available and fit the targets of SIUS, Megalink and Meyton.
- 2.4.5 The universal types must be mounted in the lower **left** corner of the frame and be powered by a USB charger or power-bank [in accordance with Rule 2.3 of this Appendix](#).

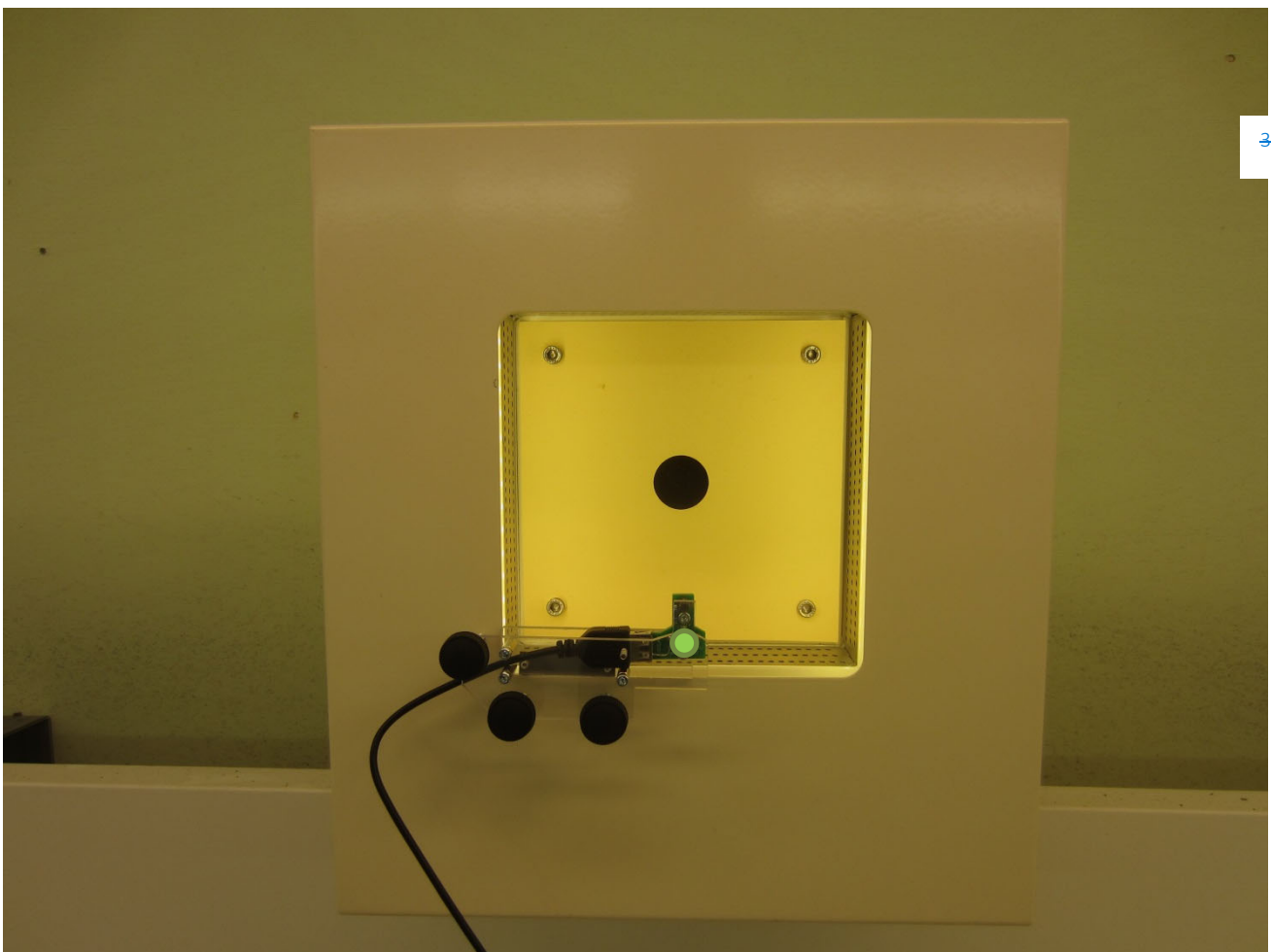

*An example of a universal IR unit mounted on a Meyton target that is powered by a USB.*



# Appendix 11

## Mixed Team Competitions



### ————RIFLE AND PISTOL MIXED TEAM EVENTS

#### ~~12.~~ 1.1 10m Air Rifle and 10m Air Pistol Mixed Team Events

##### ~~12.1.~~ General Competition Procedures

##### ~~12.1.1.~~ Events

1.1.1 This Rule (~~12~~) provides special technical rules for ~~these events:~~ the 10m Air Rifle and Air Pistol Mixed Team Events.

10m Air Rifle

##### 1.1.2 Mixed Team (standing position)

10m Air Pistol Mixed Team

##### ~~12.1.2.~~ Team Composition

~~Mixed teams~~ Two (2) Athletes from each nation (1 male & 1 female)

##### 1.1.3 National identification / Dress code

a) The athletes from each nation must ~~be display their national teams (no mixed nations) with two team members, one male and one female. Both team members should wear matching competition identification on their shooting clothing with~~ as follows:

b) Rifle: The name of the country denoted by 3 letters as determined by the IPC on their jacket pocket (or in a similar location if no jacket pocket exists) on the side which is turned to the audience. If the NOC is already on the shooting jacket, a national colours and identification flag should be placed or attached to the pocket (or similar) facing the audience.

c) Pistol: The name of the country denoted by 3 letters as determined by the IPC should be placed on the sleeve of the T-shirt/sports jacket on the side which is turned to the audience.

##### ~~12.1.3.~~ 1.1.4 Mixed Team Entries

a) Nations may enter a maximum of two teams in one ~~competition.~~ The Competition as per ISSF entry fee for each team is EUR 170 rules. Team members may be changed for other athletes registered in the ~~competition~~ Competition no later than 12:00 hours ~~before on~~ the second day before the day of the ~~competition~~ mixed team Competition.

b) The entry fee for each team will be published in the Competition general information.

##### ~~12.1.4.~~ 1.1.5 Competition Format

10m Mixed Team events will be conducted in two stages:

a) QUALIFICATION (2 parts)

b) FINALS (Consisting of a Bronze Medal Match and a Gold/Silver Medal Match)





## Appendix 11

### Mixed Team Competitions



#### 1. Qualification round

#### 2. Finals competition

### 12.1.5.1.6 Mixed Team Scores

Team scores and rankings in Mixed Teams events are based on the total scores of the two team members.

### 12.1.6.1.1.7 Coaching

a) During the qualification round, coaching will be governed by ISSF Rules (, non-verbal coaching is allowed).

b) During the final round, when commentary from the announcer is taking place medal matches, each team is allowed one (1) coach who must be seated where he/she can have access to and can communicate with their athletes. The coach may request a "Time-out" by raising a hand immediately after the completion of a round whilst the announcements are being made. This may be requested once only during each Medal Match. The Coach may approach and speak with his team members/her athlete(s) on the firing points one time (once per Final) line, for a maximum time of thirty (30) seconds. The Jury Member in Charge must control, commencing when the time limit Coach reaches the athletes.

c) The time will be controlled by the Jury member in Charge, who must announce "Time" when the thirty seconds have expired, and the Coach must immediately return to his/her seat. If a "Time-out" is requested by one team, the Coach of the other team may also approach and speak to his/her athlete(s) at the same time. This does not affect the opportunity of the other team to request their own Time-out.

### 12.1.7.1.1.8 Firearm Malfunctions

a) Malfunctions in Qualification will be governed according to ISSF Rule 6.13.

b) Malfunctions in qualification round and finals competition the Final Medal Matches will be governed according to ISSF Rules. Athletes may have only Rule 6.17.1.6. (Only one (1) allowable malfunction per stage (qualification round and finals competition), either ALLOWABLE or NON-ALLOWABLE, is permitted for each team during the Medal Match).

### 12.1.8.1.1.9 EST Complaints and Score Protests

a) EST complaints during qualification round and finals competition the Qualification will be decided according to Rule 6.16.5.2

b) See ISSF Rules. Rule 6.18.4.7 for EST complaints during Final Medal Matches.



## Appendix 11

### Mixed Team Competitions



#### 12.1.9.1.1.10 Protests

a) Protests during ~~qualification round and finals competition~~ the Qualification will be decided according to ISSF ~~Rules.~~ Rule 6.16.

b) Protests made during Finals will be decided by the Finals Protest Jury according to ISSF Rules 6.17.1.10.d and 6.17.6.

#### 12.1.10. 1.1.11 Victory Ceremonies

Victory Ceremonies for Mixed Team events will be conducted according to ~~ISSF and~~ WSPS Rules.

### 12.2. ~~Qualification Round~~

## 1.2 QUALIFICATION –Part

### 12.2.1.1.2.1 Location

~~The Mixed Team~~ Qualifications will be fired on the ~~qualification range~~ Qualification Range in one or more relays.

### 12.2.2. Start List

~~The two members of each team must be set to fire on adjacent~~ 1.2.2 Allocation of firing points with

a) The firing points of the ~~male athlete on the right and the female athlete on the left.~~ Teamsteams will be ~~set~~allocated by a random computer draw according to ISSF ~~Rules.~~ Rule 6.6.6.

b) Teams from the same nation ~~may~~must not be ~~set~~positioned next to each other.

c) Members of each team shoot next to each other.

### 12.2.3.1.2.3 Call to Line

a) For each ~~qualification~~Qualification relay, the ~~CRO~~ Chief Range Officer will call the athletes to the line fifteen(15) minutes before the scheduled start time.

b) Athletes will be allowed five (5) minutes ~~before the preparation to~~ set up their equipment on their allocated firing points.

c) Athletes ~~may not unbox their rifle/pistol nor place any equipment on their firing points until the CRO calls them to the line.~~



## Appendix 11

### Mixed Team Competitions



d) After athletes are called to the line, they are permitted to handle their rifle/pistol, remove safety flags, dry-fire and carry out holding and sighting time start. aiming exercises before the start of the Preparation and Sighting Time.

12.2.4.e) In the Final, athletes may not remove the safety flags or dry fire until the Preparation and Sighting Time starts.

#### 1.2.4 Preparation and Sighting Time

Athletes must be allowed ten (10)minutes Preparation and Sighting Time with unlimited sighting shots before the start of the match.

a) The Preparation and Sighting Time must be timed to end approximately thirty (30)seconds before the official starting time of the match.

b) Pre-competition checks by the Range Officers must be completed during the five(5)minutes before the Preparation and Sighting Time starts;

c) The Preparation and Sighting Time begins with the command “**PREPARATION AND SIGHTING TIME...START**”. No shot may be fired before the command “**START**”;

d) If an athlete fires a shot before the “**START**” command for Preparation and Sighting time, the first competition shot must be scored as a miss, (0). If safety is involved the athlete may be disqualified

e) After nine minutes and thirty seconds of the Preparation and Sighting Time have elapsed, the CRO must announce “**30 SECONDS**”;

f) At the end of the Preparation and Sighting Time, the Chief Range Officer must command, “**END OF PREPARATION AND SIGHTING...STOP**”. There will must be a brief pause of approximately thirty(30)seconds when the Target Officer will reset the targets for match firing, and;

g)If an athlete fires a shot after the command, “**END OF PREPARATION AND SIGHTING...STOP**” and before the “**MATCH FIRING...START**” command, the shot must not be counted as a match shot.

#### 1.2.5 Number of Match Shots and Time Limit

a) In Qualification Part 1, each team member will fire thirty(30) match shots (60 total shots per team), with a time limit of thirty (30)minutes. Each athlete fires independently of their partner.

#### 1.2.6 Scoring



## Appendix 11

### Mixed Team Competitions



In the Qualification rounds, decimal ring scoring (ISSF Rule 6.3.3.1) will be used for the 10m Rifle Mixed Team event. Full ring scoring will be used for the 10m Pistol Mixed Team event.

#### 1.2.7 Team Ranking

- a) The scores of each team member will be added together and the team results will be ranked. The eight (8) top-ranked teams will proceed to Qualification part 2.
- b) Ties will be broken by applying ISSF Rule 6.15.1 to the team scores (total of the two team member scores).

### 1.3 QUALIFICATION –Part 2

#### 1.3.1 Procedure

There should be a ten (10) minute preparation break between Qualification Part 1 and sighting the start of Preparation and Sighting time of Part 2.

The top eight (8) ranked teams from Qualification Part 1 will move to firing-points in a designated part of the range so that they are positioned next to each other, with a reserve firing-point between each team. Members of each team shoot next to each other. Firing-points for each team are allocated randomly by software.

Athletes who do not qualify for Part 2 should remove their equipment from the firing line as soon as possible.

#### 1.3.2 Call to Line

Athletes will be called to the line ten (10) minutes before the qualification round. This will be scheduled start time of Part 2.

If there is only one relay in Qualification Part 1 and the schedule or range conditions make it more convenient, the athletes should remain on their original firing-points for Part 2. In this case, the Chief Range Officer will command athletes to, “Take your positions” five (5) minutes before the scheduled start time of Part 2.

#### 1.3.3 Preparation and Sighting

Time Athletes who move firing points after Qualification Part 1 will have seven (7) minutes to set up their equipment followed by a 30-second pause to reset the targets. During the preparation and three (3) minutes to fire sighting shots. Athletes who remain on their original firing-points after Qualification part 1 will have two (2) minutes to take their positions followed by three (3) minutes to fire sighting time, the announcer will explain the competition format for spectators and introduce the competing teamshots.

#### 12.2.5-1.3.4 Number of Match Shots and Time Limit



## Appendix 11

### Mixed Team Competitions



In the ~~qualification round~~ Qualification Part 2, each team member will fire ~~forty (40) match~~ twenty (20) Match shots (~~80~~ 40 total shots per team), within a time limit of ~~50~~ twenty (20) minutes. ~~The qualification round~~

#### 1.3.5 Scoring

~~a) Scoring will be conducted according to as in Part 1 (ISSF Rules. Rule 6.18.2.6)~~

##### 12.2.6. Scoring

~~Decimal ring scoring will be used for the 10m Air Rifle Mixed Team qualification round. Whole ring scoring will be used for the 10m Air Pistol Mixed Team qualification round.~~

##### 12.2.7. Team Ranking

~~Teams will be ranked according to their team scores. Ties will be broken by applying ISSF Rules to the team.~~ b) Team scores from Qualification part 1 are not carried forwards to Part 2. All teams start from zero.

~~c) The scores (totals of the two each team member scores).~~

##### 12.2.8. Qualification for Final

~~will be added together and the team results will be ranked. The four (4) top five (5) ranked teams from the qualification round will advance proceed to the finals competition.~~ Finals.

#### 12.3. Finals Competition

d) Teams ranked 1st and 2nd will compete against each other in the Gold Medal Match.

e) Teams ranked 3rd and 4th will compete against each other in the Bronze Medal Match

#### 1.4 FINAL (Medal Matches)

The Final consists of a Bronze Medal Match followed by a Gold/Silver Medal Match. The procedure for conducting both Medal Matches will be the same, with appropriate wording used by the CRO in each case.

#### 12.3.1. 1.4.1 Location



## Appendix 11

### Mixed Team Competitions



10m Air-Rifle and Air-Pistol Mixed Team Finals must, if possible, be fired on a finals rangeFinals Range. Results monitors ~~must be visible to all competitors~~both members of each team must be available on the FOP.

#### 1.4.2 Procedure

- a) No bib numbers will be worn in the Medal Matches.
- b) Athletes in the Bronze Medal Match, or their Coaches, must be allowed to place their equipment on their designated firing-points at least fifteen (15) minutes before the scheduled Start time. They must then leave the range and wait to be called to the line.
- c) No bags or transport-boxes may be left on the Field of Play (FOP).

#### ~~12.3.2.~~ 1.4.3 Finals Officials

The conduct and supervision of ~~the Mixed Team~~ finals competitionFinals will be ~~done according to~~ in accordance with ISSF ~~Rules.~~ Rule 6.17.1.10.

#### ~~12.3.3.~~ Start List

~~The five teams in the finals competition will be set by a random draw on the ten (10) firing points of the finals range. Team members must be set to fire on adjacent firing points. When the team reports (30 min. before), the team coach must inform the RTS Jury which team member will shoot on the left and which team member will shoot on the right.~~

#### ~~12.3.4.~~ Scoring

~~Scores from the qualification round do not carry forward. The finals competition scoring will start from zero. All match shots in the finals competition (both rifle and pistol) will be scored with decimal scoring.~~

#### ~~12.3.5.~~ EST Complaints During Finals

~~If a team member or coach complains, or a Range Officer or Jury Member observes, that the paper strip is failing to advance, the CRO must stop the sighting period or competition, direct the Technical Officer to fix the problem and then continue firing.~~

~~If a team member complains that his target fails to register or that there is an unexpected zero or unexplained miss, the following steps must be taken:~~

- ~~a) — The Jury and Range Officer must note the time when the complaint occurred;~~
- ~~b) — The Range Officer must stop the second team member from firing and direct the athlete whose target malfunctioned to fire an additional shot. If the additional shot registers, the Range Officer will direct the team to complete the series/ shot plus 60 seconds of additional time. The value of the additional shot will be counted and the missing shot will be ignored.~~
- ~~c) — If the additional shot does not register, the Range Officer must direct the team with the target that malfunctioned to stop shooting. At the end of the series/~~



## Appendix 11

### Mixed Team Competitions



shot, the Jury must stop the competition and direct the Technical Officer(s) to repair or replace the target.

- d) — After the target is repaired or replaced, all teams will be given two (2) minutes of unlimited sighting shots. The team that had the malfunctioning target will then complete their series/shot in the time remaining when the interruption occurred plus 60 seconds of additional time. After they complete their series, the competition will continue.

#### ~~12.3.6.~~ 1.4.4 Reporting and Start Times

~~a) The start time~~ Start Time for the ~~finals competition will be~~ Final is when the CRO begins the commands for the first competition ~~series. Teams that~~ shot of the Bronze Medal Match.

~~b) All eight athletes who~~ qualify for the finals competition Final must report to the ~~finals range preparation area, with both team members, one coach and~~ Finals Range Preparation Area, with all necessary equipment, at least ~~thirty (30-)~~ thirty (30-) minutes before the ~~schedule start time~~ Start Time. A two-point (2) penalty will be deducted from the score of the first competition series if one or two team members do not report on time. Each team may be accompanied by one Coach.

~~c) If the Victory Ceremony is scheduled after the finals competition~~ Final, all athletes must report with a national team uniform appropriate for a Victory Ceremony. Juries must complete equipment checks during the reporting period and as ~~quickly as possible after the athlete reports. Team members and their coaches must be allowed to place their rifles or pistols on their assigned firing points in the FOP at least 18 minutes before the scheduled start time. Teams and their coaches must be assembled in firing point order for the call to the line at least twelve (12) minutes before the scheduled start time~~ soon as possible after each athlete reports.

~~d) Athletes in the Bronze Medal Match, or their Coaches, must be allowed to place their equipment on their designated firing-points at least fifteen (15) minutes before the scheduled Start time. They must then leave the range to wait to be called to the line.~~

~~e) Teams for each Medal Match and their Coaches must be assembled in firing point order, for the call to the line, ten (10) minutes before the Start Time.~~

#### 1.4.5 Allocation of firing points

~~a) For the Bronze Medal Match, the team ranked third after Qualification should take positions on firing points C and D, with the team ranked fourth on firing points F and G.~~





## Appendix 11

### Mixed Team Competitions



b) For the Gold/Silver Medal Match, the team ranked first after Qualification should take positions on firing points C and D, with the team ranked second on firing points F and G.

c) Team members may change positions for the Medal Matches. If a change is desired, at the time of reporting for the Final, the team Coach must inform the RTS Jury which team member will shoot on the left and which team member will shoot on the right.

#### 1.4.6 Scoring

a) All shots in the Medal Matches,(both Rifle and Pistol) will be scored with decimal scoring.

b) The team with the highest combined score in each round, compared against the other team in the Match, wins two (2) points.

c) In case of equal scores each team receives one (1) point.

d) The first team to reach sixteen (16)points or more will win the Match.

e) In case of a tie where both teams have scored at least sixteen (16)points, the Match will continue with one (1) additional shot fired by both members of each team to decide the tie.

f)If the scores are still tied the teams will continue to shoot additional shots on command until the tie is broken.

#### 1.4.7 EST Complaints during Finals

a) During the Sighting time, if a team member or coach complains, or a Range Official observes that a paper strip is failing to advance, the CRO must command athletes to stop shooting and direct the Technical Officer to fix the problem. The sighting time must then be re-started.

b) If a team member complains that his target fails to register or that there is an unexpected zero or unexplained miss, the following steps must be taken:

c)The Jury Member in Charge must direct the athlete whose target malfunctioned to fire another shot. If the additional shot registers, the value of the additional shot will be counted and the missing shot will be ignored. If the additional shot does not register, the Jury must stop the competition and move the athlete to a reserve target.

d) If an athlete is moved to a reserve target, when ready to resume, all athletes will be given two (2) minutes of unlimited sighting shots. The athlete who was moved will then fire his/her match shot in fifty (50)seconds and the competition will continue.

#### 1.4.8 Call to line

The Eight (8) minutes before the published Start time of the Medal Match, the CRO will call all athletes in the Final to the firing line by commanding “ATHLETES TO THE





## Appendix 11

### Mixed Team Competitions



**LINE.** All athletes must pause on the firing line and turn to face the spectators as the CRO announces **“LADIES AND GENTLEMEN, PLEASE WELCOME THE ATHLETES IN THE (10M10 METER AIR RIFLE/AIR PISTOL) MIXED TEAM FINAL-“BRONZE/(GOLD)MEDAL MATCH”**. After pausing for applause, the CRO will command **“TAKE YOUR POSITIONS.”** The athletes must then turn and go directly to their assigned firing points.

#### 12.3.8.1.4.9 Preparation and Sighting Time

After one (1) ~~min.,~~ minute, the CRO will command **“~~FIVE (5):~~ “THREE MINUTES PREPARATION AND, SIGHING... SIGHTING TIME...START...””**. After ~~four min.,~~ two(2) minutes and ~~thirty (30-)~~ seconds, the CRO will announce **“~~“30 SECONDS.”~~”** After ~~five—min.,~~ three(3)minutes, the CRO will command **“~~STOP...UNLOAD.~~”**

#### 12.3.9.1.4.10 Presentation of Teams in Final

After the command **“~~STOP...UNLOAD,~~”** Finalists must open ~~their gun~~ the rifle/pistol actions and insert their safety flags. Rifle finalists may remain ~~in~~ their position during the presentation, but must lower their rifles from their shoulders, keep them down throughout the presentation and turn their heads towards the spectators. Pistol finalists must lay their pistols down and turn to face the spectators for the presentation. A Range Officer must verify that ~~gun~~ their rifle/pistol actions are open with safety flags inserted. After finalists’ ~~guns~~ rifles/pistols are checked, the ~~announcer~~ Announcer will introduce the finalists, CRO and Jury Member-in-Charge according to ISSF Rules. After Rule 6.17.1.12. Immediately after the presentation, the CRO will command **“TAKE YOUR POSITIONS.”**

#### 12.3.10.—— 5-Shot Competition Series

~~The finals competition will begin with each team member shooting three (3) 5-shot series (10 total shots per team per series, 30 total shots per team). During each series the two team members must alternate firing shots (see 12.3.3 above) with the athlete on the left shooting first and the athlete on the right second (L-R-L-R-L-R etc.). Both athletes may load and prepare their firing positions after the command “LOAD,” but the athlete on the right may not shoot until the athlete on the left has fired. Teams will have 300 seconds to fire 2 x 5 shots. A two (2) point penalty will be deducted from the score of a team that shoots out of order.~~

#### 12.3.11.—— 5-Shot Competition Series Procedure

~~60 seconds after commanding “TAKE YOUR POSITIONS.”~~

The CRO will command **“1.5. MEDAL MATCH PROCEDURE”**



## Appendix 11

### Mixed Team Competitions



a) One (1) minute after the athletes have taken their positions, the CRO will command:

b) ~~“FOR THE FIRST COMPETITION SERIES...LOAD.”~~ After 5 seconds, the CRO will command ~~“START.”~~

~~After 300 seconds or after all finalists have fired~~ **COMPETITION SHOT, LOAD...** five (5) shots, the CRO will command ~~“STOP.”~~ seconds...**START”**.

c) Each team member will fire a single shot in a maximum time of fifty (50) seconds.

d) Either athlete may fire first.

e) The CRO may call **“STOP”** after all athletes have fired.

f) Immediately after the command ~~“STOP.”~~ the announcer, the team with the highest combined score of each round will be announced together with the number of points awarded.

g) The Announcer will give 15-20 seconds of comments on the current ranking of the teams and notable scores. Individual shot scores are not announced.

~~Immediately after the announcer finishes, the CRO will command “FOR THE NEXT COMPETITION SERIES...LOAD.”~~ This h) The firing sequence will ~~continue~~ be repeated until all team members have fired three (3) 5-shot series.

#### 12.3.12. Single Competition Shots

~~After each team has fired 3 x 10 shots (30 shots per team), single competition shots with each team member firing one (1) shot will begin. For each shot, the athlete on the left must shoot first and the athlete on the right second. Teams will have 60 seconds to fire their two single shots. A two (2) point penalty will be deducted from the score of a team that shoots out of order. After each team member has fired two (2) single shots, the first elimination will occur. The place of each team will be the Medal Match is decided as follows:~~

- a) ~~After each team member has fired 17 shots (15 + 2), the fifth place team will be eliminated.~~
- b) ~~After each team member has fired 19 shots (15 + 2 + 2), the fourth place team will be eliminated.~~
- c) ~~After each team member has fired 21 shots (15 + 2 + 2 + 2), the third place team will be eliminated and the bronze medal winner decided.~~
- d) ~~After each team member has fired 24 shots (15 + 2 + 2 + 2 + 3), the gold and silver medal winners will be decided.~~

#### 12.3.13. Single Competition Shots Procedure

~~Immediately after the announcer finishes commenting on the rankings and scores after the three 5-shot series, the CRO will command “FOR THE NEXT COMPETITION SHOT...LOAD.”~~ After 5 seconds, the CRO will command **“START.”**

- a) ~~After 60 seconds or after all finalists have fired one (1) shot, the CRO will command “STOP.”~~



## Appendix 11

### Mixed Team Competitions



- b) Immediately after the command **"STOP."** the announcer will give 15–20 seconds of comments on the current rankings of the teams and notable scores. Individual shot scores are not announced.
- c) Immediately after the announcer finishes, the CRO will command **"FOR THE NEXT COMPETITION SHOT...LOAD."** and this single shot sequence will continue. After all team members have fired two (2) single shots (2 x 17 total shots), the 5th place team is eliminated.
- d) After all remaining team members have fired two (2) additional single shots (2 x 19 total shots); the 4th place team is eliminated.
- e) After all remaining team members have fired two (2) additional single shots (2 x 21 total shots); the 3rd place team is eliminated.
- f) After all remaining team members have fired three (3) additional single shots (2 x 24 total shots); the 1st and 2nd place teams (gold and silver medal winners) are decided.

#### 12.3.14. Tie-Breaking

Ties for a team to be eliminated or to determine gold or silver medal winners will be broken by shoot-offs. Tied teams (both members) must fire additional tie-breaking shots, with the athlete on the left shooting first and the athlete on the right shooting second, until the tie is broken. The CRO will announce **"THERE IS A TIE BETWEEN THE TEAMS FROM (NATION) AND (NATION)"** and then conduct the shoot-off. The time limit for each tie-breaking shot is 60 seconds per team. Ties will be decided by the team totals for the tie-breaking shots.

#### 12.3.15. Finals Completion

If after the 24th shot there are no ties and the gold and silver medal winners are decided, the

#### 1.5.1 Bronze Medal Match Completion

- a) As soon as the Bronze Medal Match is decided, CRO will command **"STOP...UNLOAD"** and declare **"RESULTS ARE FINAL."** and announce the Bronze Medal Winning team.
- b) A Range Officer must verify that gun/the rifle/pistol actions are open with the safety flags inserted. ~~The~~

#### 1.5.2 Change-Over between Medal Matches

- a) The athletes in the Bronze Medal Match must leave the Field of Play to place their rifles/pistols in a safe place in the Reporting Area but may return to sit and watch the Gold/Silver Medal Match.
- b) After at least five (5) minutes, from the end of the Bronze Medal Match and after the targets have been checked by the RTS Jury and the CRO has



## Appendix 11

### Mixed Team Competitions



declared, "Range clear", athletes for the Gold/Silver Medal Match and/or their Coaches, must be allowed to place their equipment on their firing-points.

c) They must assemble then leave the three medal winning teams on range to wait to be called to the FOP and line.

#### 1.5.3 Gold/Silver Medal Match Completion

a) As soon as the announcer Medal Match is decided CRO will recognize command "STOP...UNLOAD" declare "RESULTS ARE FINAL" and announce the bronze, silver Gold and gold medal winning Silver Medal Winning teams.

b) A Range Officer must verify that the rifle/pistol actions are open with the safety flags inserted.

c) The Gold and Silver Medallists must be joined on the Field of Play by the Bronze medallists and the Jury will line them up, as in the Individual Finals, for official photographs and announcements. Athletes may be allowed to hold their rifles/pistols for the photographs so the Bronze medallists must retrieve them from the Reporting Area and return without delay.

#### 1.5.4 Finals Production and Music

a) During the Qualification stage music is allowed.

b) During the Medal Matches music should be played.

c) The Technical Delegate must approve the music program. Enthusiastic audience support is encouraged and is recommended during the Medal Matches.

#### 1.5.5 Irregular or disputed matters

ISSF General Technical Rule 6.17 will apply to matters not mentioned in the above rules. Irregular or disputed matters will be decided by the Jury according to General Technical Rules for each event

