



World  
**Shooting**  
Para Sport

World Shooting Para Sport

# Technical Rules and Regulations

May 2022

## Table of contents

Introduction .....	6
Definitions .....	6
WSPS Regulations.....	10
<b>1 General Provisions.....</b>	<b>10</b>
1.1 Scope and application .....	10
1.2 Interpretation .....	11
1.3 Governance.....	11
1.4 Printing of These Rules and Regulations .....	12
1.5 Amendments to These Rules and Regulations.....	12
<b>2 Competition Regulations.....</b>	<b>13</b>
2.1 Events.....	13
2.2 Competition Levels and Programmes.....	14
2.3 Competition Management .....	14
2.4 Local Organising Committee (“LOC”).....	15
2.5 Athlete Eligibility .....	15
2.6 Qualification requirements .....	16
2.7 Gender.....	16
2.8 Anti-Doping.....	17
2.9 International Classification .....	17
2.10 Technical Meeting.....	18
2.11 Start Number .....	18
2.12 Technical Protests and Appeals.....	19
2.13 Penalties for Rule Violations .....	19
2.14 Disqualification .....	20
2.15 Disciplinary Action .....	20
2.16 Coaching During Any Event.....	21
2.17 Results.....	21

2.18	Rankings.....	21
2.19	Records.....	25
<b>WSPS Rules .....</b>		<b>27</b>
<b>3</b>	<b>Apparel and Equipment Rules .....</b>	<b>27</b>
3.1	Compliance with ISSF dress code .....	27
3.2	WSPS-specific dress code provisions (jackets, trousers and footwear).....	27
3.3	Equipment .....	29
3.4	Equipment Control .....	30
3.5	Strapping .....	31
3.6	Trigger extensions and adaptations.....	31
3.7	Shooting Chairs .....	32
3.8	Shooting Tables.....	36
3.9	SH2 Support stands .....	39
<b>4</b>	<b>Rifle Rules.....</b>	<b>41</b>
4.1	Events and times .....	41
4.2	Shooting positions .....	43
4.3	Loaders (SH2 only) for Qualification Rounds .....	46
<b>5</b>	<b>Pistol Rules .....</b>	<b>47</b>
5.1	Events and times .....	47
5.2	Shooting position.....	48
5.3	Loading device (safety).....	48
<b>6</b>	<b>Shotgun Rules .....</b>	<b>49</b>
6.1	Events and times .....	49
6.2	Shooting position.....	49
6.3	Loading device (safety).....	50
6.4	Other.....	51
<b>7</b>	<b>Vision Impaired (VI) Rules .....</b>	<b>52</b>
7.1	Events and times .....	52
7.2	Apparel and Equipment.....	52

7.3	Shooting Positions.....	54
7.4	VI Assistant .....	55
<b>8</b>	<b>Team Event Rules.....</b>	<b>56</b>
8.1	Events and format .....	56
8.2	Team size.....	56
8.3	Maximum number of teams per NPC .....	56
8.4	Event viability.....	56
8.5	Mixed Team .....	56
<b>9</b>	<b>Medical Rules.....</b>	<b>57</b>
9.1	Return to Field of Play Decisions.....	57
9.2	Epilepsy .....	57
9.3	Pacemakers .....	57
<b>Appendix 1</b>	<b>Requirements &amp; Designation of Competitions</b>	
<b>Appendix 2</b>	<b>Recognised Competition Requirements</b>	
<b>Appendix 3</b>	<b>Sanctioned &amp; Approved Competition Requirements</b>	
<b>Appendix 4</b>	<b>Bib templates</b>	
<b>Appendix 5</b>	<b>Equipment Control Sheet</b>	
<b>Appendix 6</b>	<b>Trigger Extensions &amp; Adaptions</b>	
<b>Appendix 7</b>	<b>SH2 Support Stand &amp; Springs</b>	
<b>Appendix 8</b>	<b>P5 10m Air Pistol Standard</b>	
<b>Appendix 9</b>	<b>Athlete Epilepsy Declaration</b>	
<b>Appendix 10</b>	<b>VI Shooting Technical Specifications</b>	
<b>Appendix 11</b>	<b>Mixed Team Competitions</b>	



## Introduction

### Preamble

These World Shooting Para Sport (“WSPS”) Rules and Regulations are mandatory for all WSPS Recognised Competitions. The overall governance and management of all World Para Sports (including WSPS) is subject to the detailed provisions of the IPC Handbook.

Section 1 and 2 of this document will consist of the WSPS Regulations. Sections 3-9 will consist of the WSPS Rules.

### Governance

The IPC acts as the International Federation for the sport of shooting Para sport. It is responsible for, amongst other things, organising international Competitions and drawing up rules and regulations relevant to the sport of shooting Para sport, and ensuring that they are followed. IPC carries out its responsibilities as International Federation under the name “World Shooting Para Sport”, and the term “World Shooting Para Sport” should therefore be read in these Rules and Regulations as being equivalent to IPC.

### World Shooting Para Sport Classification Rules and Regulations

The WSPS Classification Rules and Regulations are an integral part of these Rules and Regulations and are available at: [www.paralympic.org/shooting/rules-and-regulations/classification](http://www.paralympic.org/shooting/rules-and-regulations/classification). Terms which are defined in the WSPS Classification Rules and Regulations and appear in these Rules and Regulations shall have the meaning given to them in the WSPS Classification Rules and Regulations, unless otherwise defined in these Rules and Regulations.

### Changes to These Rules and Regulations

Please note that these Rules and Regulations may be changed at any time as a result, for example, of changes in the ISSF Rules, Classification-related matters or where WSPS otherwise considers it necessary to do so.

## Definitions

**Classification:** grouping athletes into Sport Classes (as defined in the IPC Athlete Classification Code) according to how much their Impairment affects fundamental activities in each specific sport or discipline. This is also referred to as “Athlete Classification”.

**Classification Panel:** a group of Classifiers, appointed by WSPS, to determine Sport Class and Sport Class Status in accordance with the WSPS Classification Rules.

**Competition:** a series of individual and mixed team events conducted together under one ruling body.

**Competition Jury:** the person(s) appointed to adjudicate WSPS Competitions.

**Eligible Impairment:** as defined in the IPC Classification Code.

**Equipment Control:** the process of checking an athlete's equipment to ensure it complies with these Rules and Regulations.

**Event:** a single event that takes place at a Competition, for example the R4 Event.

**Finals:** the final round Competition that takes place after the qualification round is complete.

**Firing Line:** the "starting line" that marks the appropriate distance to the target. This is the line that all athletes must be behind when competing.

**ID Card:** an official picture card that can identify the athlete, such as a passport.

**International Classification:** Classification that takes place with a WSPS-appointed Classification Panel in accordance with the WSPS Classification Rules and Regulations.

**International Federation:** a sport federation recognised by the IPC as the sole world-wide representative of a sport for athletes with an Eligible Impairment that has been granted the status as a Para sport by the IPC. The IPC and IOSDs act as an International Federation for certain Para sports.

**IOC:** the International Olympic Committee.

**IOSD:** International Organisation of Sport for the Disabled, an independent organisation recognised by the IPC as the sole worldwide representative for a specific Eligible Impairment group to the IPC.

**IPC:** the International Paralympic Committee.

**IPC Games:** the Paralympic Games and IPC Regional Games.

**IPC Handbook:** The IPC Handbook located on the IPC's website at <https://www.paralympic.org/ipc-handbook>

**IPC Regional Games:** regional games in which the IPC is the organising body, such as the Parapan American Games.

**ISSF:** the International Shooting Sport Federation.

**ISSF Rules:** the in-force version of the International Shooting Sport Federation Rules including the ISSF General Regulations, General Technical Rules, Rifle Rules, Pistol Rules, and Shotgun Rules, as amended from time to time.

**Loader:** a Team Official who will assist athletes with loading during Competitions.

**Malfunctions:** this includes both allowable and non-allowable malfunctions in Pistol, as defined in the ISSF Rules.

**Minimum Qualifying Score (“MQS”):** a list of qualification scores, per Event and Sport Class, an athlete must achieve to enter the Competition. MQS scores shall be defined by WSPS for a specific Competition.

**National Federation:** the national member of an International Federation.

**NPC:** National Paralympic Committee, the national member of the IPC who is the sole representative of athletes with an Eligible Impairment in that country or territory.

**Para sport:** a sport governed by the IPC Athlete Classification Code and recognised as a Para sport by the IPC.

**Physical Impairment (“PI”):** as defined in the WSPS Classification Rules and Regulations.

**Programme of Events:** the Programme of Events is a list of Events/days in the order they are going to be competed.

**Range Official:** an official appointed by the LOC with WSPS approval to ensure compliance with these WSPS Rules and Regulations at a Competition.

**shooting Para sport:** the sport of shooting Para sport governed by WSPS and recognised as a Para sport by the IPC.

**Sport Class:** as defined in the WSPS Classification Rules and Regulations.

**Sport Class Status:** as defined in the WSPS Classification Rules and Regulations.

**Team Leader:** an accredited Team Official who is the main point of contact for their delegation.

**Team Official:** an accredited team member (non-athlete) who represents their delegation.

**Technical Delegate:** a Competition Jury member appointed by WSPS to monitor and oversee a WSPS Competition and to ensure all technical operations are conducted in accordance with these Rules and Regulations.

**Technical Meeting:** a meeting for all teams which takes place before IPC Games, WSPS Championships and WSPS Sanctioned Competitions to disseminate information on technical matters and logistics related to the Competition.

**VI Assistant:** a Team Official who supports VI athletes during the Competition as determined by these Rules and Regulations.

**Vision Impairment (“VI”):** as defined in the WSPS Classification Rules and Regulations.

**WADA:** the World Anti-Doping Agency.

**WADC:** the World Anti-Doping Code.

**WSPS:** World Shooting Para Sport.

**WSPS Approved Competitions:** international and national level Competitions for the sport of shooting Para sport that have been approved by WSPS.

**WSPS Championships:** Shooting Para Sport World Championships and WSPS Regional Championships.

**WSPS License:** a license card issued by WSPS in accordance with the WSPS Athlete Registration and Licensing Regulations to enable athletes to compete in IPC Games, WSPS Championships and WSPS Sanctioned Competitions.

**WSPS Official:** WSPS-certified officials.

**WSPS Athlete Registration and Licensing Regulations:** The World Shooting Para Sport Athlete Registration and Licensing Regulations, as published on the WSPS website and updated from time to time.

**WSPS Nationality Policy:** The World Shooting Para Sport Nationality Policy, as published on the WSPS website and updated from time to time.

**WSPS Recognised Competitions:** IPC Games, WSPS Championships, WSPS Sanctioned Competitions and WSPS Approved Competitions.

**WSPS Sanctioned Competitions:** Shooting Para Sport World Cups and other shooting Para sport international Competitions as determined by WSPS.



## WSPS Regulations

### 1 General Provisions

#### 1.1 Scope and application

- 1.1.1 These Rules and Regulations comprise the WSPS Regulations (“**Regulations**”) and the WSPS Rules (“**Rules**”), together with the Appendices listed above. The Appendices form an integral part of these Rules and Regulations.
- 1.1.2 These Rules and Regulations are mandatory for all WSPS Recognised Competitions.
- 1.1.3 WSPS will enforce the ISSF General Technical Rules in the areas of Safety, Targets and Target Standards, Ranges and Other Facilities, Gauges and Instruments, Competition Clothing and Equipment, Competition Jury Duties and Functions, Organizing Committee Competition Officials, EST Competition Operations, Competition Procedures, Rules of Conduct for Athletes and Officials, Malfunctions, Scoring and Results Procedures, Tie-Breaking, and Protests and Appeals, unless a WSPS Rule specifies otherwise.
- 1.1.4 WSPS will enforce ISSF Rifle Rules in the areas of Safety, Range and Target Standards, Rifles and Ammunition, and Clothing Regulations, unless a WSPS Rule specifies otherwise.
- 1.1.5 WSPS will enforce ISSF Pistol Rules in the areas of Safety, Range and Target Standards, Equipment and Ammunition, Athletes Shoes, Shooting Accessories, Interruptions and Irregularities, and Malfunctions in 25m Events, unless a WSPS rule specifies otherwise.
- 1.1.6 WSPS will enforce ISSF Shotgun Rules in the areas of Safety, Range and Target Standards, Equipment and Ammunition, Competition Officials, Targets – Regular, Irregular, Broken, Hit, Lost and No Targets, Competition Rules for Trap, Malfunctions, Competition Clothing and Equipment, Results, Timing and Scoring (RTS) Procedures Ties and Shoot-Offs, Rule Violations, and Protests and Appeals, unless a WSPS rule specifies otherwise.
- 1.1.7 When there is a conflict between any ISSF Rule and these Rules and Regulations, these Rules and Regulations will apply. In the event of a dispute relating to ISSF Rules in relation to any aspect of a WSPS Recognised Competition, including as to whether such a conflict exists or whether any ISSF Rule(s) applies, WSPS will make the final decision as to its resolution, acting in its sole discretion.

- 1.1.8 All participants (including, but not limited to, athletes and support personnel, coaches, trainers, managers, interpreters, Team Officials, medical or paramedical personnel) in any WSPS Recognised Competitions agree to be bound by these Rules and Regulations as a condition of such participation.
- 1.1.9 The WSPS Classification Rules and Regulations are an integral part of these Rules and Regulations and are located on the WSPS website.
- 1.1.10 The IPC Handbook is an integral part of the governance of the sport of shooting Para sport.
- 1.1.11 Any matter not addressed in these Rules and Regulations shall be determined by WSPS, in its sole discretion.
- 1.1.12 This version of these Rules and Regulations will be effective from 1 January 2022, and shall prevail over all previous versions of these Rules and Regulations.

## 1.2 Interpretation

- 1.2.1 Capitalised terms used in these Rules and Regulations have the meaning given to them in the Definitions section above.
- 1.2.2 Any comments annotating various provisions of these Rules and Regulations shall be used to interpret these Rules and Regulations.
- 1.2.3 Headings used in these Rules and Regulations are used for convenience only and have no meaning that is separate from the Regulation(s) or Rule(s) to which they refer.
- 1.2.4 All references to the words “he”, “his” or “him” in these Rules and Regulations also mean the words “she”, “hers” or “her”.

## 1.3 Governance

- 1.3.1 The IPC acts as the International Federation for and governs the sport of shooting Para sport. It carries out these responsibilities under the name “World Shooting Para Sport” (“WSPS”) and the term “World Shooting Para Sport” (“WSPS”) must be read in these Rules and Regulations as the IPC and vice versa.

## **1.4 Printing of These Rules and Regulations**

1.4.1 These Rules and Regulations are the copyright property of the IPC and have been published for the benefit of NPCs, athletes, Team Officials and others who are engaged in an official capacity with WSPS. They may be reprinted or translated by any organisation with a legitimate need to do so, subject to IPC's continuing ability to assert its copyright in them, including the right to insist on an assignment to the IPC of the copyright in any translated version. Any other organisation must obtain the permission of the IPC prior to reprinting, translating or publishing these Rules and Regulations.

1.4.2 The English version of these Rules and Regulations shall be accepted as the authoritative version for the purpose of interpretation.

## **1.5 Amendments to These Rules and Regulations**

1.5.1 These Rules and Regulations may be amended at any time by WSPS for any reason, including, for example, as a result of changes in Classification-related matters, the ISSF Rules, or where WSPS otherwise considers it necessary to do so.

## 2 Competition Regulations

### 2.1 Events

2.1.1 The Events recognised by WSPS as Events for the purposes of the sport of shooting Para sport are:

Event	Discipline	Gender	Class
R1	10m Air Rifle Standing	Men	SH1
R2	10m Air Rifle Standing	Women	SH1
R3	10m Air Rifle Prone	Mixed	SH1
R4	10m Air Rifle Standing	Mixed	SH2
R5	10m Air Rifle Prone	Mixed	SH2
R6	50m Rifle Prone	Mixed	SH1
R7	50m Rifle 3 Positions	Men	SH1
R8	50m Rifle 3 Positions	Women	SH1
R9	50m Rifle Prone	Mixed	SH2
P1	10m Air Pistol	Men	SH1
P2	10m Air Pistol	Women	SH1
P3	25m Pistol	Mixed	SH1
P4	50m Pistol	Mixed	SH1
*P5	10m Air Pistol Standard	Mixed	SH1
*PT1	Trap Seated	Mixed	SG-S
*PT2	Trap Standing (Lower Limb)	Mixed	SG-L
*PT3	Trap Standing (Upper Limb)	Mixed	SG-U
*VIS	10m Air Rifle VI Standing	Mixed	SH-VI
*VIP	10m Air Rifle VI Prone	Mixed	SH-VI
*MTR1	Mixed Team 10m Air Rifle Standing SH1	Mixed	SH1
*MRT2	Mixed Team 10m Air Rifle Standing SH2	Mixed	SH2
*MTP	Mixed Team 10m Air Pistol	Mixed	SH1

\*Non Paralympic Events

## 2.2 Competition Levels and Programmes

2.2.1 WSPS categorises Competitions based on their scale, size, and nature to determine the applicable requirements at each Competition.

2.2.2 WSPS Recognised Competitions levels are as follows:

<b>IPC Games</b>	<ul style="list-style-type: none"> <li>▪ Paralympic Games</li> <li>▪ Parapan American Games*</li> </ul>
<b>WSPS Championships</b>	<ul style="list-style-type: none"> <li>▪ WSPS World Championships</li> <li>▪ WSPS Regional Championships</li> </ul>
<b>WSPS Sanctioned Competitions</b>	<ul style="list-style-type: none"> <li>▪ WSPS World Cups</li> <li>▪ Any other WSPS International Competitions determined by WSPS (such as Youth Games, IOSD Games, Asian Para Games)</li> </ul>
<b>WSPS Approved Competitions</b>	<ul style="list-style-type: none"> <li>▪ International Competitions, also called “Grand Prix”, for the sport of shooting Para sport or National Federation-endorsed Competitions</li> <li>▪ Any other Competitions for the sport of shooting Para sport as determined by WSPS</li> </ul>

\*This applies only to the Santiago 2023 Parapan American Games

2.2.3 For an overview of the requirements for each level of WSPS Recognised Competition, see the ‘Designation of Competitions’ (available as Appendix 1).

## 2.3 Competition Management

2.3.1 WSPS shall have the right to manage and shall have ultimate jurisdiction over all matters related to WSPS Championships and WSPS Sanctioned Competitions (and may delegate or remove such jurisdiction to the Competition Jury or other officials under these Rules and Regulations or as it sees fit) and shall have the power to postpone Events and give directions consistent with rules adopted for conducting any Event. WSPS shall also have the right to oversee all WSPS Approved Competitions.

2.3.2 WSPS shall have the right to intercede as necessary in order to resolve any conflicts or issues in any WSPS Recognised Competition, including by requiring an LOC to address any aspect of the Competition or issue in relation to the WSPS Rules and Regulations.



- 2.3.3 The words ‘World’, ‘Regional’ and ‘World Shooting Para Sport’ may not be used in connection with any shooting Para sport Competition or Event without the prior written consent of WSPS. In addition, the IPC is the owner of all rights of whatever kind or nature in respect of the terms “Paralympics” and “Paralympic”, the term “Para” when associated with sport or any IPC activities, the IPC motto, flag and anthem, the Paralympic Symbol (three Agitos design) and any other trademarks, logos and other indicia used or intended to be used in the context of the Paralympic Movement.
- 2.3.4 For further details of competition management requirements for WSPS Recognised Competitions, please refer to Appendix 2.
- 2.3.5 For further details of competition management requirements and related hosting requirements for WSPS Sanctioned and WSPS Approved Competitions, please refer to Appendix 3.

## **2.4 Local Organising Committee (“LOC”)**

- 2.4.1 An LOC is the organisation responsible for organising and hosting a Competition.
- 2.4.2 For WSPS Recognised Competitions (excluding IPC Games), the LOC must be endorsed by and shall have its structure subject to approval by WSPS.
- 2.4.3 The LOC, in conjunction with WSPS, shall be responsible for the entire management of the Competition, including the arrangement of the Programme of Events, arrangement for the Classification of athletes, all technical equipment and installation prior to and during Competition.

## **2.5 Athlete Eligibility**

### **2.5.1 Eligibility requirements – IPC Games**

The IPC determines the eligibility requirements for IPC Games.

### **2.5.2 Eligibility requirements – WSPS Championships and WSPS Sanctioned Competitions**

To meet the eligibility requirements to participate in WSPS Championships and WSPS Sanctioned Competitions an athlete must:

- 2.5.2.1 satisfy the requirements of the WSPS Nationality Policy (this will be available in 2022);
- 2.5.2.2 have a WSPS License issued in accordance with the WSPS Athlete Registration and Licensing Regulations by the time of the final entry deadline;

- 2.5.2.3 be in possession of a valid ID Card and WSPS License Card (to be carried at all times during Competitions);
- 2.5.2.4 be entered by their NPC (or National Federation if such responsibility has been delegated by the NPC), in either case the NPC being a member in good standing of the IPC;
- 2.5.2.5 meet the relevant Competition eligibility criteria, as defined in the Competition Information Package and/or Qualification Guide;
- 2.5.2.6 be internationally classified and have been assigned a Sport Class (other than Not Eligible (NE)) in accordance with the WSPS Classification Rules and Regulations, or in the case of 'New' athletes, have been determined by WSPS to have an Eligible Impairment in accordance with the WSPS Classification Rules and Regulations; and
- 2.5.2.7 not be disqualified, suspended or otherwise sanctioned.

### **2.5.3 Eligibility requirements – WSPS Approved Competitions**

In order to compete in WSPS Approved Competitions an athlete must meet the eligibility requirements determined by the relevant LOC or governing body.

## **2.6 Qualification requirements**

- 2.6.1 In addition to the eligibility requirements listed above, in order to compete in WSPS Recognised Competitions an athlete must also meet the qualification standards, qualification criteria and any sport entry rules applicable to the relevant Competition.

## **2.7 Gender**

- 2.7.1 Subject to Regulation 2.7.3 below, an athlete shall be eligible to compete in men's Competition if he is:
  - 2.7.1.1 recognised as male in law; and
  - 2.7.1.2 eligible to compete under these Rules and Regulations.
- 2.7.2 Subject to Regulation 2.7.3 below, an athlete shall be eligible to compete in women's Competition if she is:
  - 2.7.2.1 recognised as female in law; and
  - 2.7.2.2 eligible to compete under these Rules and Regulations.

- 2.7.3 WSPS will deal with any cases involving transgender athletes in accordance with the IOC's transgender guidelines (as amended by the IOC from time to time) and any applicable WSPS regulations.
- 2.7.4 The eligibility of persons recognised as third gender in law will be determined by the WSPS on a case-by-case basis, in accordance with any applicable WSPS regulations.

## **2.8 Anti-Doping**

- 2.8.1 The IPC Anti-Doping Code (located on the IPC website) applies to all IPC Games, WSPS Championships and WSPS Sanctioned Competitions.
- 2.8.2 WSPS Approved Competitions must be conducted in accordance with the anti-doping rules of the relevant governing body and the WADC International Standards. WSPS strongly recommends that Doping Control take place at all WSPS Approved Competitions.

## **2.9 International Classification**

- 2.9.1 International Classification may be conducted in connection with a WSPS Recognised Competition. Classification must always take place in accordance with the WSPS Classification Rules and Regulations.
- 2.9.2 Prior to the Competition a list and timetable for those athletes required to be present for Classification will be created by WSPS. Athletes and NPCs will be informed accordingly of their appointment time by WSPS.
- 2.9.3 In accordance with the WSPS Classification Rules and Regulations, all athletes with Sport Class Status 'New', 'Review' or 'Review' with a 'Fixed Review Date' in the Competition calendar year must attend an Athlete Evaluation Session before competing at any WSPS Recognised Competition, if an Athlete Evaluation Session is available for them at that Competition.
- 2.9.4 Subject to the terms of Regulations 2.5 and 2.9.3 above, and unless specified otherwise in the Competition entry requirements, at any WSPS Recognised Competition:

- 2.9.4.1 in accordance with Article 15.3 of the WSPS Classification Rules and Regulations, athletes with Sport Class Status ‘New’ may compete but their results will not be recognised, and they will not be eligible to win medals at that Competition. WSPS may retroactively recognise the athlete’s results for MQS purposes only, acting in its sole discretion, in the event that a ‘New’ athlete is subsequently allocated the same Sport Class in which they competed as ‘New’ athlete; and
- 2.9.4.2 in accordance with Article 15.5.2 of the WSPS Classification Rules and Regulations, athletes who have Sport Class Status ‘Review’ or ‘Review’ with a ‘Fixed Review Date’ in the Competition calendar year may compete, win medals and have their results recognised in that Competition.

## 2.10 Technical Meeting

- 2.10.1 Unless otherwise specified by WSPS, before the start of each WSPS Recognised Competition the LOC, together with the Technical Delegate, must organise a Technical Meeting with representatives of the participating countries and the LOC, supervised by the Technical Delegate.
- 2.10.1.1 The Technical Delegate is responsible for overseeing all technical matters at the Competition in accordance with these Rules and Regulations.
- 2.10.1.2 Whenever possible, the Technical Delegate will communicate any specific advice or requirements related to technical matters for the Competition at the Technical Meeting.

## 2.11 Start Number

- 2.11.1 A start number must be assigned to each athlete and appear on all Competition lists and timetables.
- 2.11.2 The athlete start numbers are printed on bibs, which are produced by WSPS and printed and distributed by the LOC.
- 2.11.3 SH2 athletes who are permitted to use a Loader(s) (denoted by ‘(L)’ on the athlete bib) will also be issued a Loader bib.
- 2.11.4 VI Assistants will be assigned a VI Assistant bib (denoted by ‘(A)’ on the athlete bib).
- 2.11.5 The bib size and design must be as shown in **Appendix 4**.

- 2.11.6 The bib must be visible at all times when the athlete (and/or Loaders/VI Assistant) is on the field of play.
- 2.11.6.1 Athletes with **backrest score A**: the bib must be worn on the back of the athlete.
  - 2.11.6.2 Athletes with **backrest score B or C**: the bib must be displayed on the back of the Shooting Chair (as the bib cannot obscure the view of the free sitting height marking tape).
  - 2.11.6.3 **Loaders and VI Assistants**: must wear the bib on their back. The bib must be properly fixed/pinned (so as not to move around) at the top and bottom to the shirt above the waistline during the entire Competition.
- 2.11.7 In the case that the bib is issued to an athlete (and/or Loaders/VI Assistants) but not displayed, the athlete may not commence/continue to shoot in the Event.

## 2.12 Technical Protests and Appeals

- 2.12.1 Any violation by an athlete, Team Official, team member or any other individual of these Rules and Regulations (as determined by WSPS) will be resolved in accordance with the procedures set out in these Rules and Regulations and the ISSF Rules.
- 2.12.2 All protests and appeals regarding technical matters will be resolved in accordance with the procedures described in the ISSF Rules, following these Rules and Regulations, documentation and forms (available on the WSPS website).
- 2.12.3 All protests and appeals regarding Classification matters will be handled in accordance with the WSPS Classification Rules and Regulations.
- 2.12.4 The fee for a technical protest or appeal is to be determined in accordance with ISSF Rules, unless otherwise specified by WSPS.
- 2.12.5 If a technical protest or appeal is denied the protest or appeal fee will be retained by WSPS.

## 2.13 Penalties for Rule Violations

- 2.13.1 The Competition Jury must decide Rules violations by athletes at Competitions in accordance with the following procedures:



- 2.13.1.1 In the case of an open violation of the Rules (i.e. where no attempt is made by the athlete or other member of their team to conceal the violation), a warning ('Yellow Card') must first be given so the athlete may have an opportunity to correct the fault. Whenever possible, the warning should be given during training or the preparation and sighting time. If the athlete does not correct the fault as instructed by the Competition Jury, two (2) points must be deducted from their score ('Green Card'). If the athlete still does not correct the fault after receiving a deduction ('Green Card'), then disqualification ('Red Card') ('DSQ') must be imposed.
- 2.13.1.2 In the case of a concealed violation of the Rules, (i.e. where an attempt is made by an athlete or member of their team to conceal the violation) disqualification ('Red Card') ('DSQ') must be imposed.

## 2.14 Disqualification

- 2.14.1 In addition to any specific provisions of these Rules and Regulations providing for disqualification, an athlete, Team Official, team member or any other individual may have their accreditation withdrawn and/or be disqualified from any Event(s) or Competition(s) by WSPS, if, in the reasonable opinion of WSPS, they:
- 2.14.1.1 contravene the spirit of fair-play or obstruct members of any committee, WSPS Officials or the Competition Jury in his/her official duties;
- 2.14.1.2 behave in a manner which may actually or potentially bring into disrepute WSPS, the IPC, any International Federation and/or the LOC; or
- 2.14.1.3 breach any protocol or procedure put in place by an LOC and/or WSPS for an Event or Competition (for example in relation to the health, safety or security of athletes, including any protocol put in place in relation to the coronavirus pandemic).

## 2.15 Disciplinary Action

- 2.15.1 Further disciplinary action, including in relation to situations that are not covered by these Rules or Regulations or ISSF Rules, may be taken against any individual bound by these Rules and Regulations on a case-by-case basis by the WSPS Technical Delegate, in consultation with WSPS. Further action(s) may be taken at WSPS' discretion.

## **2.16 Coaching During Any Event**

### **2.16.1 Verbal Coaching**

- 2.16.1.1 Verbal coaching during training and preparation time is permitted, but such coaching must not disturb other athletes.
- 2.16.1.2 During training and preparation time coaches are permitted to approach the Firing Line to verbally coach their athlete(s) (unless prohibited by a member of the Competition Jury).
- 2.16.1.3 During Competition, coaches are permitted to approach the Firing Line only following a specific request by their athlete(s) or a VI Assistant and a member of the Competition Jury permits this request.
- 2.16.1.4 Subject to 2.16.1.3, while on the Firing Line during Competition, all athletes may speak only with a member of the Competition Jury or a Range Official (except SH2 athletes who may speak with their Loader as required).
- 2.16.1.5 In R7/R8 Finals, verbal coaching is allowed only during changeover times.

### **2.16.2 Non-Verbal Coaching**

- 2.16.2.1 In all Events, non-verbal coaching is permitted, but such coaching must not disturb other athletes.

### **2.16.3 Violation of Coaching Regulation**

- 2.16.3.1 If a Team Official or athlete violates any provision of this Regulation 2.16 during any Event, a warning must be issued for a first offence in that Event. For each further violation in that Event, two (2) points must be deducted from the athlete's score and the Team Official must leave the vicinity of the Firing Line.

## **2.17 Results**

- 2.17.1 Unless specified otherwise in these Rules and Regulations, scoring procedures for all WSPS Recognised Competitions must be followed as described in the ISSF Rules.

## **2.18 Rankings**

- 2.18.1 WSPS shall maintain world and regional rankings to determine the best performing athletes per Event per season, based on a points system, by considering both the rank and the result achieved by the athletes.

2.18.2 Rankings shall be calculated on a rolling basis. The rolling ranking will include all WSPS Recognised Competitions from one year ago to the day. (Example: on 15 April 2023, rankings will include all results achieved in WSPS Recognised Competitions from 15 April 2022 - 15 April 2023).

2.18.3 Only athletes who have a WSPS License and have a Sport Class Status 'Review', 'Review' with a 'Fixed Review Date' or 'Confirmed' can have their results recognised for ranking purposes.

#### 2.18.4 **Performance Points**

2.18.4.1 After each WSPS Championships and WSPS Sanctioned Competition, athletes will obtain performance points based on their performance.

2.18.4.2 Athletes will be ranked in descending order according to their performance points.

2.18.4.3 Athletes will receive ranking points depending on their performance as outlined below.

2.18.4.4 Performance points will be allocated following the ratification of the Competition results, and are calculated based on the following values:

a) Value A (rank points) - based on the rank achieved in the qualification and final rounds.

b) Value B (Competition weighting) - based on the level and significance of the Competition.

c) Value C (qualification result points) - based on the qualification score achieved by the athlete, divided by the world record (as of 1 January of the Competition year) in that Event.

2.18.4.5 The total performance points will be calculated and published to two decimal places (mathematically rounded).

#### 2.18.5 **Duration of validity**

The time for which the allocated performance points remain valid will vary according to the level and significance of the WSPS Recognised Competition:

Competition	Code	Duration of validity (seasons)
Paralympic Games	PG	2
WSPS World Championships	WCH	2
Regional Games/Championships ( <i>only valid for Regional Rankings</i> )	RG	1
WSPS World Cups/Sanctioned Competitions	WC	1

2.18.5.1 Points obtained at the Paralympic Games and World Championships will remain valid in the ranking system for two years from the date of Competition.

2.18.5.2 Performance points obtained at all other WSPS Sanctioned Competitions and IPC Regional Games will be valid in the ranking system for one year.

### 2.18.6 Value A (Rank Points)

2.18.6.1 The Value 'A' allocated will be determined by the rank an athlete achieves, both in the qualification and final rounds.

2.18.6.2 A point value is allocated based on the rank in the Qualification Rounds (value A1) and Final Round (value A2):

Rank	Qualification Round Points (A1)	Final Round Points (A2)
1st rank	11	50
2nd rank	10	40
3rd rank	9	30
4th rank	8	20
5th rank	7	18
6th rank	6	16
7th rank	5	14
8th rank	4	12
9 <sup>th</sup> + rank	1	0

2.18.6.3 Value A is calculated as a sum of the points for the qualification and final ranking (values A1 + A2).

$$\text{Qualification Rank Points (A1)} + \text{Final Rank Points (A2)} = \text{Value A}$$

2.18.6.4 For non-Paralympic Events where no Finals are conducted, in the ranking calculations a value of zero will be assigned for the Final Rank Points (value A2).

2.18.6.5 If an athlete ranks 1-8 in qualification but is DNS (“Did Not Start”) in the final, in the ranking calculations a value of zero will be assigned for the Final Rank Points (value A2).

### 2.18.7 Value B (Competition weighting)

2.18.7.1 The Value B allocated will vary according to the level and significance of the Competition:

Competition	Code	Value B
Paralympic Games	PG	10
World Championships	WCH	8
Regional Games/Championships ( <i>only valid for Regional Rankings</i> )	RG	6
World Cup	WC	6

### 2.18.8 Value C (qualification result points)

2.18.8.1 The Value C allocated is the Qualification Score achieved by the athlete, divided by the World Record in that Event (as of 01 January of the Competition year).

2.18.8.2 For both World and Regional Rankings, the World Record will be used.

$$\frac{\text{Qualification Score}}{\text{World Record}} = \text{Value C}$$

### 2.18.9 Calculation

2.18.9.1 Performance points per Competition are calculated by multiplying together Values A, B and C.

<b>Value A</b> (Rank points)	x	<b>Value B</b> (Competition weighting)	x	<b>Value C</b> (Qualification result points)	=	<b>Performance Points</b>
---------------------------------	---	---	---	---	---	---------------------------



## 2.19 Records

- 2.19.1 World, regional and junior records may be established in WSPS Events R1-R9, P1-P5, MTR, MTP, PT1-PT3, VIS, and VIP.
- 2.19.2 IPC Games records may be established only at the Paralympic/Regional Games in the relevant Events.
- 2.19.3 Only scores obtained at WSPS Championships or WSPS Sanctioned Competitions will be eligible for records recognition.
- 2.19.4 The Technical Delegate must submit the record report form at the end of the Competition in order for records to be ratified and recognised.

### 2.19.5 Junior records

- 2.19.5.1 Junior records will be recognised at world record level only.
- 2.19.5.2 To be eligible to obtain junior records, athletes must be under the age of 21 on 31 December of the year of the relevant Competition.

### 2.19.6 Records definitions

2.19.6.1 The obtainable WSPS records are as follows:

Record	Type	Code	Description
World Record	New	WR	a) <b>Paralympic Events:</b> record to be established in the final of the relevant Event using the Finals result only; b) <b>Non-Paralympic Events:</b> record to be established in the qualification round of the relevant Event using the qualification result only. c) <b>Paralympic Events:</b> record to be established in the qualification round of the relevant Event using the qualification result only; d) <b>Non-Paralympic Events:</b> there will be no qualification record established in non-Paralympic Events.
	Equal	EWR	
Junior World Record	New	WRJ	
	Equal	EWRJ	
Regional Record	New	[Region]	
	Equal	E[Region]	
Qualification Record	New	QR	
	Equal	EQR	
Junior Qualification Record	New	QRJ	
	Equal	EQRJ	
Regional Qualification Record	New	Q[Region]	
	Equal	EQ[Region]	
Team Record	New	WR	e) Team records will be established in team Events using the combined qualification scores of the 3 nominated team members.
	Equal	EWR	
Team Regional Record	New	[Region]	
	Equal	E[Region]	

Paralympic Record	New	PR	f) Paralympic records will be established in the Paralympic Games Final of the relevant Event using the Finals result only.
	Equal	EPR	
Paralympic Qualification Record	New	PQR	g) Paralympic qualification records will be established in the Paralympic Games qualification round of the relevant event using the qualification result only.
	Equal	EPQR	
Regional Games Record	New	GR	h) Games records will be established in the relevant Regional Games final of the relevant Event using the Finals result only.
	Equal	EGR	
Regional Games Qualification Record	New	GQR	i) Games qualification records will be established in the relevant Regional Games qualification round of the relevant Event using the qualification result only.
	Equal	EGQR	

## WSPS Rules

### 3 Apparel and Equipment Rules

#### 3.1 Compliance with ISSF dress code

- 3.1.1 All persons on the field of play and ceremonies area must adhere to the ISSF dress code.
- 3.1.2 Athletes must also comply with the WSPS-specific dress code provisions as set out in Rule 3.2 below.

#### 3.2 WSPS-specific dress code provisions (jackets, trousers and footwear)

##### 3.2.1 Shooting Jackets (“WSPS Jacket”)

- 3.2.1.1 The maximum length of the shooting jacket may not be longer than down to the lap in front and down to the top of the cushion in back.
- 3.2.1.2 The length of the jacket will be measured in standing shooting position.
- 3.2.1.3 The athlete must not sit on any part of their shooting jacket during Competition.
- 3.2.1.4 SH1B, SH1C and SH2 rifle athletes must use a WSPS Jacket. Athletes shooting on the floor in the prone position may use an ISSF jacket.
- 3.2.1.5 All SH1A rifle athletes may use an ISSF jacket in accordance with the ISSF Rules, in the following circumstances:

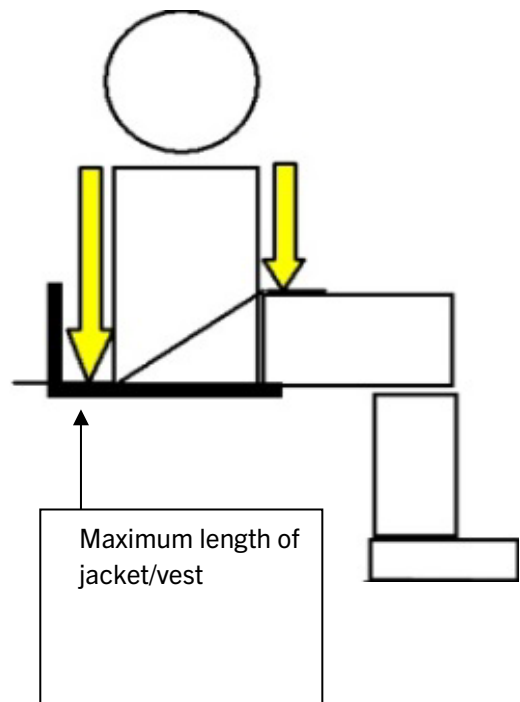

Position	Style	Regulation
Kneeling	Shooting as per ISSF position	Permitted: Jacket usage as per ISSF Rules
	Shooting from a Shooting Chair	Permitted: Only the top 3 jacket buttons may be fastened, and the buttons may not extend below the bottom of the ribcage or equivalent. Any additional buttons must not be used.
Prone	Shooting as per ISSF position	Permitted: Jacket usage as per ISSF Rules
	Shooting from a Shooting Chair	Permitted: Only the top 3 jacket buttons may be fastened, and the buttons may not extend below the bottom of the ribcage or equivalent. Any additional buttons must not be used.
Standing	Shooting from a high stool or free-standing	Permitted: Jacket usage as per ISSF Rules
	Shooting from a Shooting Chair	ISSF jacket not permitted

3.2.1.6 A maximum of 1 WSPS Jacket and 1 ISSF jacket per athlete must be approved by Equipment Control in each Competition.

3.2.1.7 Jackets without buttons

- a) Even if the jacket has no buttons, the jacket must be shaped in accordance with Rules 3.2.1.1 and 3.2.1.2 above.

### 3.2.2 Shooting Trousers

3.2.2.1 Shooting Trousers are prohibited for SH1B, SH1C and all SH2 athletes.

3.2.2.2 Shooting trousers are permitted for SH1A athletes shooting in the standing position from a high stool or free-standing position or in the kneeling position as per the ISSF position set out in the ISSF Rules.

- 3.2.2.3 Athletes with lower limb prosthesis/prostheses are permitted to keep their shooting trousers on in the kneeling (from a Shooting Chair) and prone position, only if:
- a) they are unable to remove their trousers due to a prosthesis; and
  - b) the leg zippers and waistband of the trousers are open when in position.

### 3.2.3 Footwear

- 3.2.3.1 Footwear must be worn by all persons on the field of play unless prescribed otherwise on their classification card.
- 3.2.3.2 An athlete may be permitted to wear orthopaedic footwear or other non-ISSF dress code compliant footwear (e.g. sandals) if there is a valid medical reason. In all cases unless WSPS determines otherwise:
- a) such exceptions will be assessed and decided by the Classification Panel and recorded on the athlete's Classification and WSPS License; and
  - b) such footwear will not be tested for flexibility during Equipment Control.

## 3.3 Equipment

- 3.3.1 Athletes must use only equipment that complies with and is in accordance with these Rules and Regulations and the ISSF Rules. Any equipment that the Competition Jury deem may give an athlete an unfair advantage or is not expressly permitted in these Rules and Regulations is prohibited.
- 3.3.2 All equipment must be supplied by the athlete.
- 3.3.3 Athletes and their equipment must be within the designated area of their firing point and behind the Firing Line.
- 3.3.3.1 An exception may be made for rifle resting stands, which will be permitted in accordance with the ISSF Rules.
- 3.3.4 For athletes shooting from a Shooting Chair (not including a high stool), the centreline of the barrel must not exceed more than 150cm (measured from the floor).
- 3.3.5 SH2 athletes are permitted to add material that gives increased grip for the hands on the rifle. However:



- 3.3.5.1 The material must still allow free movement of the athlete and rifle;
- 3.3.5.2 The rifle needs to remain within the specified dimensions; and
- 3.3.5.3 The adaption must adhere to Rule 3.3.1.

### **3.4 Equipment Control**

- 3.4.1 Team Leaders and coaches are equally responsible for ensuring that athletes' equipment and apparel comply with these Rules and Regulations and the ISSF Rules.
- 3.4.2 ISSF equipment will be checked in accordance with the ISSF Rules.
- 3.4.3 **WSPS-specific equipment**
  - 3.4.3.1 'WSPS-specific equipment' is defined as:
    - a) Strapping
    - b) Prosthesis
    - c) Shooting table(s)
    - d) Compensating block
    - e) 10cm block
    - f) Shooting Chair(s)
    - g) SH2 rifle support stand
    - h) Loading device (Pistol)
    - i) Trigger extensions and adaptations
  - 3.4.3.2 WSPS-specific equipment checks will be done in accordance with these Rules and Regulations.
  - 3.4.3.3 The athlete is responsible for submitting WSPS-specific equipment and apparel for official inspection and approval before the start of every Competition. As part of this process:
    - a) The athlete must present both their valid ID Card and WSPS License; and
    - b) The 'Equipment Control Sheet' (Appendix 5) must be completed and signed by all relevant parties.
  - 3.4.3.4 Each athlete's equipment may be checked by the Competition Jury on the Firing Line prior to the start of each Event.
- 3.4.4 Random equipment checks will be done by the Competition Jury from Equipment Control directly after an Event.

### 3.5 Strapping

- 3.5.1 Athletes are not allowed to hold or touch the straps when competing to gain stability.
- 3.5.2 Straps must not exceed 5cm in width.
- 3.5.3 Below knee: it is permitted to have 1 below knee strap to the Shooting Chair.
- 3.5.4 Above knee: the legs may be strapped together once above the knees but not to the chair.
- 3.5.5 In SH1/SH2A Events, in the case of athletes with double above-knee amputation (and not using any prosthesis), a strap across the stumps and strapped to the chair is permitted.

### 3.6 Trigger extensions and adaptations

- 3.6.1 In accordance with the ISSF Rules, the style/shape of a trigger is a personal choice as long as it stays within the boundary of the given dimensions (as stated in the ISSF Rules regarding 'Depth of fore-end' and 'Maximum thickness (breadth) of the fore-end').
- 3.6.2 The shape of the trigger is free; however the trigger must remain safe and stay within the permitted dimensions.
  - 3.6.2.1 **Trigger extension:** triggers that have modifications compared to standard triggers, but are inside the dimensions of the ISSF Rules and protected by a trigger guard.
  - 3.6.2.2 **Trigger Adaptions:** triggers that have modifications compared to standard triggers, and are outside of the trigger guard and dimensions of the ISSF Rules (**see Appendix 6**).
- 3.6.3 Trigger adaptations are only permitted in the following circumstances:
  - 3.6.3.1 Athletes must have a medical reason to use a trigger adaptation.
  - 3.6.3.2 The athlete's request to use a trigger adaptation must be reviewed and approved by a WSPS Classification Panel during a technical assessment (in consultation with the Technical Delegate, regarding the safe use of the proposed trigger adaptation).
  - 3.6.3.3 If approved, the trigger adaptation must be recorded on the athlete's Classification card and WSPS License.

## 3.7 Shooting Chairs

3.7.1 A “**Shooting Chair**” is any object on which an athlete sits to shoot. This includes wheelchairs, chairs, seats, stools and high stools.

3.7.1.1 A high stool allows athletes to compete with their feet on the ground adopting a standing position while supported by a seat. WSPS shall have final discretion as to whether any object shall be deemed a high stool. All athletes competing on high stools during Rifle Events must comply with the following rules:

- a) the minimum height of the seat must be equal to or higher than the athlete’s mid-thigh height. The mid-thigh height is the mid-measurement between the knee joint to the hip joint (measured along the femur bone);
- b) the maximum height of the seat is the measurement of the athletes inside leg length minus 7 cm;
- c) the measurement of the base of the stool must be no greater than 60X60 cm. The base of the stool must be 3 or 4 independent legs. The base may not connect the legs;
- d) the seat must be circular or rectangular. Use of a bike seat is permitted for athletes with an amputation at the hip(s) joint;
- e) the athlete’s feet must not touch the base of the high stool; and
- f) both feet of the athlete must be in front of the forward part of the seat.

3.7.2 All Shooting Chairs will be checked with the athlete in the shooting position during Equipment Control and will be subject to spot checks on the Firing Line before, during or immediately after the Competition. Any disputes will be resolved by WSPS or the Technical Delegate in their absolute discretion

3.7.3 Athletes using wheelchairs as Shooting Chairs must be able to remove themselves from the Firing Line without any artificial assistance.

3.7.3.1 For the purposes of this Rule, examples of artificial assistance include any tool used to lock a Shooting Chair onto the firing point (for example a screwdriver).

3.7.3.2 For the avoidance of doubt, the wheelchair’s brakes shall not constitute artificial assistance for the purposes of this Rule.

3.7.3.3 Nothing in this Rule shall prevent another individual (for example a Coach or Loader) from providing physical assistance (e.g. pushing a wheelchair) in removing an athlete from the Firing Line.

3.7.4 The guidelines for armrests, sideboards and table per discipline are summarised below.

Position	Armrests	Sideboards	Table
<b>Kneeling</b>	Authorised only if the armrests are used to attach the table, however, the arm rests must not provide additional trunk support or stability (see Rule 4.2.1.2 ).	Not authorised.	Authorised, however the table frame must not provide additional support or stability in any way (see Rule 4.2.1.2).
<b>Prone</b>	Authorised only if the armrests are used to attach the table.	Authorised, however they must not provide additional trunk support or stability.	Authorised (however with restrictions as stipulated in Rule 4.2.2.1).
	The arm(s) of the Shooting Chair which are not used to attach the table/board must be removed.		
<b>Standing</b>	Not authorised. Refer to rule 4.2.3.2	Not authorised. Refer to rule 4.2.3.2	Not authorised.

3.7.5 Handles and side posts may not exceed the height of the backrest.

3.7.6 The height of the wheels of the wheelchair may not exceed the height of the athlete’s hip when in the sitting position. An athlete’s hip is not allowed to touch the wheels.

3.7.7 Subject to the other terms of this Rule 3.7, it is not permitted to add any material or modify the structure of the Shooting Chair to gain stability of the pelvis or the spine and thus gain an unfair advantage.

3.7.7.1 Athletes are not permitted to adjust their electronic chairs during Competitions, including Finals unless permitted by a member of the Competition Jury.

3.7.8 Athletes must not lean on the side posts or wheels of their Shooting Chairs to gain stability of the pelvis or the spine and thus gain unfair advantage.

- 3.7.8.1 The sides of the torso may touch the side posts; however, it is not permitted for athletes to use the side posts to gain additional stability of the spine.
- 3.7.8.2 The spine must not be in contact with the post when the athlete is in the shooting position.

**3.7.9 Seating pad/cushion:**

3.7.9.1 All cushions thinner than 5cm are permitted.

3.7.9.2 Cushions thicker than 5cm are permitted only if they are compressible to a maximum depth of 5cm when the athlete is sitting in the shooting position.

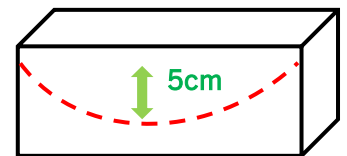

3.7.9.3 Stacked cushions (consisting of a non-compressible booster/block – used to adjust the level of the sitting height, with a compressible cushion on top) are permitted. However, as stated above, the compressible cushion part must be compressible only to maximum depth of 5cm when the athlete is sitting in the shooting position.

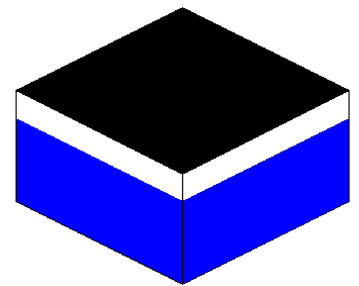

3.7.9.4 Testing of the compression of the cushion is completed at Equipment Control, and may also be checked on the Firing Line.

3.7.9.5 Any programmable air cell cushion is prohibited.

**3.7.10 Sitting angle and backrest angle**

3.7.10.1 The sitting angle and backrest angle is free; however the axis of the wheelchair from side-to-side must be horizontal ( $\pm 5$  degrees).

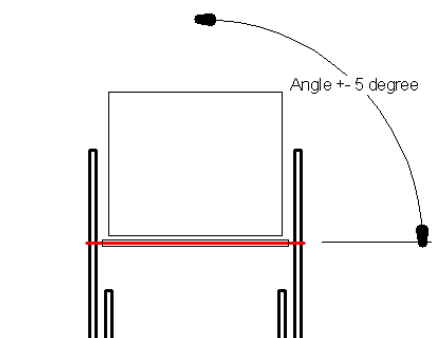

**3.7.11 Backrest slack**

3.7.11.1 The backrest may be made of hard or flexible material:

- a) Backrests made from flexible material: the maximum slack (stretch) of the backrest (the distance from the front of the vertical side posts of the backrest to the deepest part of the backrest) shall not exceed 8cm;
- b) Backrests made from hard material: the backrest may be flat or with a curved surfaced; however the maximum slack (depth of the curve) of the backrest (the distance from the front of the vertical sides of the backrest to the deepest part of the backrest) shall not exceed 3cm. If the backrest is upholstered with compressible material, the maximum depth of the curve must still not exceed the permitted depth of 3cm when the material is compressed.

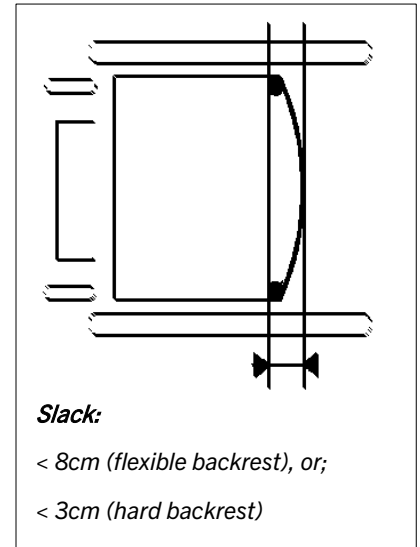

3.7.11.2 Backrest slack is to be measured with the athlete in the Shooting Chair in the shooting position.

### 3.7.12 Visible Free Height

#### 3.7.12.1 Score A

- a) A back-support of any height may be fitted to the Shooting Chair in such a way that athletes may take a rest against it between shots.
- b) There must be clearly no contact between athlete and back-support when firing.

#### 3.7.12.2 Score B

- a) A minimum of 60% of the total back length of the athlete needs to be above the backrest.
- b) The measurement will be taken the middle of vertebra C7 - vertebra prominence.

- c) The measurement will be recorded on the athlete's Classification and WSPS License as the minimum 'Visible Free Height'.

#### 3.7.12.3 **Score C**

- a) The measurement will be taken the middle of vertebra C7 - vertebra prominence.
- b) The measurement will be recorded on the athlete's Classification and WSPS License as the minimum 'Visible Free Height'.

3.7.12.4 No part of the backrest may be higher than the minimum Visible Free Height as specified in the athlete's WSPS License.

3.7.12.5 The Competition Jury shall:

- a) measure the Visible Free Height of each athlete and ensure that it is not shorter than the minimum Visible Free Height indicated on the athlete's Classification and Licence Cards;
- b) place a piece of tape on the back of the athlete's shooting jacket to indicate the Visible Free Height (the Visible Free Height will be indicated by the bottom edge of the tape). The tape must be visible at all times.

### 3.8 Shooting Tables

#### 3.8.1 Rifle Events

3.8.1.1 **Size** - all components of the shooting table (regardless of shape or form) must:

- a) be of a size no larger than 90cm in diameter;
- b) remain within the firing point dimensions.

3.8.1.2 **Shape**

- a) Shooting tables may have a small upstanding edge fitted to prevent small items from falling (but in no way may be used for additional stability or support of the athlete).
- b) The shape of the shooting table is free.

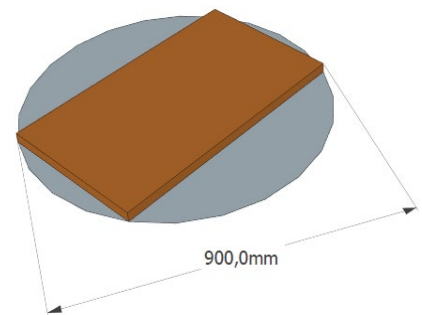



- c) If the shape of the table is curved (as in 'U-Form'), the shape of the curve must be wider than the athlete's torso, so that the left and right side of the athlete's abdomen cannot touch the table at the same time when in the prone position.

**3.8.1.3 Form - the construction of the shooting table may:**

- a) Either be attached to the Shooting Chair or free standing;  
 b) Consist of a single table, or a multiple small individual tables;  
 c) If two or more small individual tables are used:

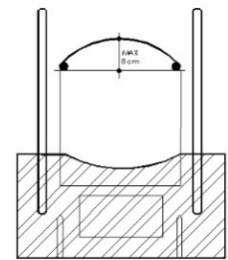

- I. They must be joined or placed together in such a way as to provide one stable platform; and  
 II. The combined surface of the tables must meet all requirements as specified for shooting tables (size, angle, shape).

**3.8.1.4 Angle**

- a) The shooting table must be horizontal or at the same angle as the floor (measured at the centre of the table).  
 b) A variation of  $\pm 5$  degrees is allowed.  
 c) Athletes with uneven upper limbs may be permitted to use a compensating block under the shorter limb when shooting in the prone position. This shall be assessed by the Classification Panel and marked on the athlete's Classification and WSPS License if permitted.

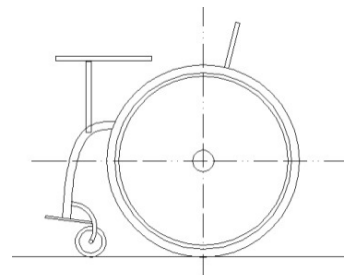

**3.8.1.5 Support**

- a) The shooting table must not be used to gain support or stability for the body in any way, except for in the prone position.  
 b) In the prone position, the table can provide support (but athletes are not allowed to gain stability on the left or right side of the chair with the abdomen).

#### 3.8.1.6 Upholstering

- a) The table or board may be upholstered with compressible material of a maximum thickness of 2cm.
- b) The material on the table must be of uniform thickness for both elbows.
- c) It is not permitted to make a hollow in the table or board or in the upholstered material.

#### 3.8.1.7 Elbow support table in the kneeling position

- a) The maximum surface for support of the elbow in the kneeling position is 10cm in diameter. This support can be from:
  - I. a small shooting table (10cm surface diameter); or
  - II. an additional mounted support (hereafter '10cm block') added to the larger shooting table: a removable board with a diameter of 10cm and a thickness of at least 20mm.

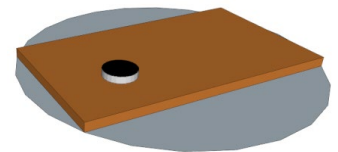

#### 3.8.1.8 Shooting stand support

- a) An additional separate board or table may be allowed for the rifle rest.

### 3.8.2 Pistol Tables

3.8.2.1 In the event that the range bench is fixed to the ground so the athlete cannot get close enough to rest and load the pistol, or the bench is designed in such a way that means the athletes' shooting position is compromised and cannot safely operate the loading procedure, the use of an additional small table may be permitted:

- a) the additional table must be presented at Equipment Control;
- b) the Competition Jury from Equipment Control will make an assessment on a case-by-case basis and will confirm if the use of an additional small table will be permitted; and
- c) the use of the table will be checked on the Firing Line by the Competition Jury to confirm that the table is used in a safe manner by the athlete.

3.8.2.2 The additional table (if permitted) must be within the following specifications:

- a) Maximum size of 30cm x 30cm.
- b) Maximum height of 100cm.
- c) The table must in no way provide additional support to the athlete in the shooting position.

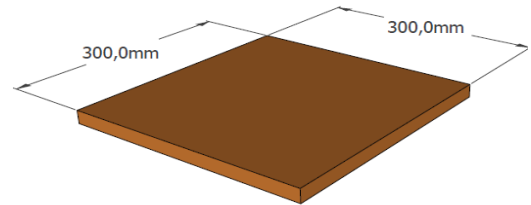

### 3.9 SH2 Support stands

- 3.9.1 All SH2 athletes must use an approved support stand (see **Appendix 7**) to support the weight of the rifle.
- 3.9.2 The Classification Panel will assess muscle power in the shooting arm (arm used to shoulder the rifle) for athletes in Sport Class SH2 for the purpose of identifying if the athlete may use a weak or a strong spring on the rifle support.
- 3.9.3 Depending on the athlete’s assessment score, they will be allocated a subclass; ‘a’ or ‘b’.
- 3.9.4 This subclass will be recorded on the athlete’s Classification and WSPS License and determines which spring the athlete shall use in their support stand:

Subclass	Spring Characteristics
a	WEAK SPRING (white plastic part) = flexibility minimum 35mm
b	STRONG SPRING (black plastic part) = flexibility minimum 25mm

- 3.9.5 The shooting stand may be fixed to the table or on a tripod.
- 3.9.6 No other support or mechanical devices may be used as a support for the rifle.
- 3.9.7 No device or substance may be attached to the rifle or the shooting stand in order to hold the rifle in a fixed position in, or against the shooting stand.
- 3.9.8 The athlete’s hands must not be placed in front of the spring or interfere with the operation of the spring when firing a shot.
- 3.9.9 The pin and the spring of the shooting stand must be in vertical position, front to back.

- 3.9.10 It is allowed to shorten the bottom part of the support stand. The remaining length needs to be at least 20mm, so that it will be possible to check the flexibility of the support stand during Equipment Control.
- 3.9.11 **Yoke (rifle holder)**
- 3.9.11.1 The rifle may not contact both sides of the yoke at the same time.
  - 3.9.11.2 The yoke must be at least 1cm wider than the width of the rifle stock.
  - 3.9.11.3 It is allowed to add material inside the yoke as long as it is comparable to the surface of a shooting glove and doesn't interfere with the yoke measurements.
- 3.9.12 **Point of balance**
- 3.9.12.1 The point of balance of the rifle must be marked at equipment check. The rifle must be placed  $\pm 5$ cm of its point of balance on the rifle support stand and the total 10cm range must be marked. The complete yoke must be within the 10cm range.
  - 3.9.12.2 The point of balance on gas or compressed air rifles will be measured with full containers.
  - 3.9.12.3 The total weight of the upper part of the support stand must be less than 200 grams. The spring must be an official WSPS-approved model (see **Appendix 7**).
- 3.9.13 **Test bar for spring flexibility (Appendix 7)**
- 3.9.13.1 Weight and tolerances for testing the flexibility of the springs are:
    - a) Bar 1) 250 Grams  $+2 - 0$  (used for zeroing)
    - b) Bar 2) 720 Grams  $+0 - 2$  (used to test the flexibility)
  - 3.9.13.2 All springs must be checked at Equipment Control prior to Competition according to Appendix 7.
  - 3.9.13.3 All springs must have the open turn and must be marked in the position at which the spring passes the test, and the spring must be used in this same position during the Competition as described in Appendix 7.
  - 3.9.13.4 An athlete may use two different springs (10m and 50m) during a Competition. Both springs must successfully go through Equipment Control.

## 4 Rifle Rules

### 4.1 Events and times

4.1.1 All rifle Event times are in accordance with these Rules and Regulations.

4.1.2 WSPS Competitions may comprise the following rifle Events (the “Rifle Events”):

Event	Discipline	Gender	Class	Shots	Time Electronic Targets	Time Target carriers & pit-operated Competitions
R1	10m Air rifle standing	Men	SH1	60	1:15	1:30
R2	10m Air rifle standing	Women	SH1	60	1:15	1:30
R3	10m Air rifle prone	Mixed	SH1	60	0:50	1:00
R4	10m Air rifle standing	Mixed	SH2	60	1:15	1:30
R5	10m Air rifle prone	Mixed	SH2	60	1:00	1:10
R6	50m Rifle prone	Mixed	SH1	60	0:50	1:00
R7	50m Rifle 3 positions	Men	SH1	40 kneeling 40 prone 40 standing	2:45	3:15
R8	50m Rifle 3 positions	Women	SH1	40 kneeling 40 prone 40 standing	2:45	3:15
R9	50m Rifle prone	Mixed	SH2	60	1:00	1:10
*MTR1	Mixed Team Rifle Standing SH1	Mixed	SH1	30 + 30	0:30	N/A
*MTR2	Mixed Team Rifle Standing SH2	Mixed	SH2	30 + 30	0:30	N/A

\*Non-Paralympic Event

- 4.1.3 It is recommended that in Events R3, and all SH2 events at least every third firing point is left vacant to avoid the disturbance of other athletes. The final decision on this matter will be made by the Technical Delegate.
- 4.1.4 In the R7 and R8 Events, one coach/team member is permitted to assist the athlete in the changeover time between positions; however, athletes must lead and actively participate in the changeover process.
- 4.1.4.1 If the athlete is not actively participating in the changeover process (for example, assisting with rifle adjustments) the penalty for a first violation in a Competition will be first a yellow card, followed by a green card (two (2) point penalty) for a second violation in that Competition, with a third violation in that Competition resulting in a red card (disqualification).
- 4.1.5 No unused equipment or additional chairs may be left on the field of play.
- 4.1.6 Athletes may not use chairs to rest their equipment on.
- 4.1.7 **Finals**
- 4.1.7.1 The ISSF Rules regarding timings of Events will be followed in all Finals, unless specified by WSPS. Refer to the WSPS Finals Commands document available on the WSPS website.
- 4.1.7.2 During the final, Loaders must move to the back of firing point (1m behind the athlete) between shots. During the single shot series, the Loader must wait until “stop” is commanded before returning to the athlete. Loaders must be loading during the finals to be allowed on the field of play.
- 4.1.7.3 Athletes (and Loaders) must ensure they do not touch the rifle with a pellet/bullet before the command “LOAD” is given.
- 4.1.7.4 The loading process must be completed within 5 seconds from the command “LOAD” being given, except in SH2 Events, where athletes/Loaders must complete the loading process within 10 seconds from the command “LOAD” being given.
- 4.1.7.5 If eliminated from the final, all athletes (including SH2) must immediately leave their firing point and move to the side of field of play to their allocated place next to their coach. Coaches/Loaders may assist athletes in this process.

## 4.2 Shooting positions

### 4.2.1 Kneeling

4.2.1.1 SH1A athletes with lower limb deficiency are able to compete in the ISSF kneeling position using prosthesis or a stool of 35cm maximum height (if marked on the athlete's Classification Card) to support the rifle-supporting leg.

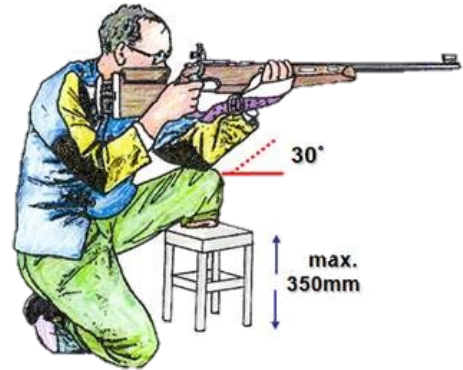

4.2.1.2 If a Shooting Chair and table is used:

- the athlete must comply with WSPS Rules 3.7 and 3.8;
- only one elbow must rest on the table or board and the body must be well clear of the board;
- the supporting forearm must form an angle of not less than 30 degrees from the horizontal. Only the point of the elbow may be supported on the 10cm block;
- no support may be gained from the board/table frame/arm rests;
- the arm(s) of the Shooting Chair (which are not used to attach the table/board to) must be removed.

### 4.2.2 Prone

4.2.2.1 All athletes (SH1 & SH2) are not allowed to fixate their body between the backrest and the table; they may either lean on the backrest or the table for stability but not both.

4.2.2.2 Should an athlete have uneven upper limb lengths, it is permitted to use a compensating block (under the shorter limb). This shall be assessed by the Classification Panel and marked on the athlete's Classification and WSPS License if permitted.

4.2.2.3 **50m Rifle Prone:** athletes may choose to compete either in the position as described in the ISSF Rules, or with the use of a Shooting Chair and table.

4.2.2.4 **10m Air Rifle prone:** athletes may not lie down but must use a Shooting Chair and table.



#### 4.2.2.5 SH1

- a) Both elbows must rest on the table or board.
- b) The upper arms must not touch the table or board (it is recommended that the part of the table below the upper arm is removed).
- c) The forearm must not form an angle of less than 30 degrees from the horizontal, measured from the axis of the forearm.
- d) In the case of upper limb deficiency athletes: it is permitted to hold the rifle with a normal prosthesis, if the prosthesis does not grip the rifle and does not have a fixed elbow.
- e) Both the forearms and the sleeves of the shooting jacket must be visibly raised from the surface of the table as per ISSF rules.

#### 4.2.2.6 SH2

- a) Use of a sling is prohibited.
- b) Both elbows (if the athlete's Impairment allows) must rest on the table or board.
- c) If the athlete's Impairment does not allow for both elbows to be rested on the table, the athlete may rest their non-shooting arm on the table, on top of the rifle, or on their body, provided that the arm is visibly relaxed and not used in such a way as to gain additional support and an unfair advantage.
- d) The upper arms must not touch the table or board (it is recommended that the part of the table below the upper arm is removed).

### 4.2.3 Standing

4.2.3.1 Athletes with a trunk function score A may choose to compete free-standing (if so, they must stand free of any artificial support, with the exception of medically certified normal prosthesis/orthosis).

4.2.3.2 The arms and sideboards of the Shooting Chair and the shooting table must be removed (if the construction of the wheelchair requires a sideboard, the height of this may not exceed the height of the top of the wheel by more than 10mm).

4.2.3.3 When shooting from a high stool, the athlete must be able to remove his/her feet from the floor, without losing balance and without moving the upper body.

4.2.3.4 **SH1**

- a) The rifle must be held with the arms only, without support (as per the ISSF Rules).
- b) No part of the arms may come in contact with any part of the Shooting Chair.
- c) Not any part of the elbows is to make contact with the lap, wheel or gain support other than from the ribcage, hip or abdomen. The penalty for noncompliance with this rule is first a Yellow Card, followed by a Green Card (two (2) point penalty), with a 3rd violation resulting in a Red Card (disqualification).

4.2.3.5 **SH2**

- a) In the case of arm-amputee athletes it is not permitted to hold (touch) the rifle with the prosthesis in standing position.
- b) In the standing position all athletes must clearly and visibly de-shoulder (removal of physical contact between butt plate and shoulder) the rifle in between shots. There must be a visible separation of at least 3cm between every shot.
- c) The penalty for not de-shouldering between shots will be first a Yellow Card, followed by a Green Card (two (2) point penalty), with a 3rd violation resulting in a Red Card (disqualification).



### 4.3 Loaders (SH2 only)

- 4.3.1 Loaders apply only to SH2 athletes competing in SH2 Events and are permitted only as described in the WSPS Classification Rules and Regulations.
  - 4.3.1.1 A Classification Panel makes the decision as to whether an athlete is permitted to have a Loader and the outcome will be marked on the athlete's Classification and WSPS License.
- 4.3.2 The Loaders must:
  - 4.3.2.1 not speak or give signals during the match;
  - 4.3.2.2 only load the rifle and/or adjust the sights at the request of the athlete, not support the rifle.
- 4.3.3 In SH2 Qualification Events, every third (3rd) firing point will be left free. This free firing point must be used as space for the Loaders.
  - 4.3.3.1 Depending on the firing point allocated, Loaders must stand to the left or right of their athlete as specified by the allocated firing point.
  - 4.3.3.2 The Loader's position (left/right of the athlete) is fixed according to the firing point and cannot be changed to the other side of the athlete.
  - 4.3.3.3 Loaders must stay in position for the duration of the Competition and must not move to the back of the firing point between shots.
- 4.3.4 If the Loader is also the athlete's coach, they must first ask permission of the range officer before speaking to each other, in accordance with Rule 2.16 above.

## 5 Pistol Rules

### 5.1 Events and times

5.1.1 All pistol Event times are in accordance with these Rules and Regulations.

5.1.2 WSPS Competitions may comprise the following pistol Events (the “Pistol Events”):

Event	Discipline	Gender	Class	Shots	Time Electronic Targets	Time Target carriers & pit-operated Competitions
P1	10m Air Pistol	Men	SH1	60	1:15	1:30
P2	10m Air Pistol	Women	SH1	60	1:15	1:30
P3	25m Pistol	Mixed	SH1	60	-	-
P4	50m Pistol	Mixed	SH1	60	1:30	1:45
*P5	10m Air Pistol Standard	Mixed	SH1	40-	-	-
*MTP	Mixed Team Pistol	Mixed	SH1	30 + 30	0:30	N/A

\*Non-Paralympic Event

5.1.3 P3 Event is to be shot according to the ISSF 25m Pistol Rules.

5.1.3.1 If the bench of the 25-meter range is too high for sitting athletes to perform the 45-degree angle in the ready position, the ‘ready position’ can be accepted as the lowest point to the surface of the bench.

5.1.3.2 In no case may the pistol rest on the bench during the ready position.

5.1.3.3 Athletes may request this modified ready position. The decision to allow the modified ready position is at the discretion of the Technical Delegate.

5.1.4 P5 (10m Air Pistol Standard) Event is to be shot in accordance with the Rules as set out in **Appendix 8**.

5.1.5 No equipment or additional chairs may be left on the field of play.

5.1.6 Athletes may not use chairs to rest their equipment on.

#### 5.1.7 **Finals**

5.1.7.1 The ISSF Rules regarding timings will be followed in all Finals as set out in the 'WSPS Finals Commands' document available on the WSPS website. Athletes must ensure they do not touch the pistol with a pellet/bullet before the command "LOAD" is given.

5.1.7.2 The loading process must be completed within five (5) seconds from the command "LOAD" being given in Events P1, P2, and P4.

5.1.7.3 If eliminated from the Final, all athletes must immediately leave their firing point and move to the side of field of play to their allocated place next to their coach. Coaches may assist athletes in this process.

## 5.2 **Shooting position**

5.2.1 SH1A athletes may choose to compete free-standing. If so, they must stand free of any artificial support, except for medically certified normal prosthesis/orthosis.

5.2.2 The arms and sideboards of the Shooting Chair and the shooting table must be removed.

5.2.3 The non-shooting arm/hand must not be on the Shooting Chair or in a position to give the athlete an unfair advantage (in accordance with the ISSF Rules).

5.2.4 Any additional items between the legs and the non-shooting arm (such as a cushion) are not allowed.

## 5.3 **Loading device (safety)**

5.3.1 Loading safety must follow the ISSF Rules, except for Rule 5.3.2 below.

5.3.2 A loading device, to hold the pistol to enable it to be loaded or unloaded safely, must always be used if it is specified on the athlete's Classification card and WSPS License following Classification of the athlete by the Classification Panel.

5.3.2.1 The loading device will be checked at Equipment Control by the Competition Jury to ensure safe handling.

## 6 Shotgun Rules

### 6.1 Events and times

6.1.1 All Shotgun Events and times are in accordance with these Rules and Regulations.

6.1.2 WSPS Competitions may be comprised of the following shotgun Events (the “Shotgun Events”):

Event	Discipline	Gender	Class	Shots	Targets	Preparation Time Limits
*PT1	Trap Seated	Mixed	SG-S	125	Day 1 – 75 Targets Day 2 – 50 Targets	15 sec
*PT2	Trap Standing (Lower Limb)	Mixed	SG-L	125	Day 1 – 75 Targets Day 2 – 50 Targets	15 sec
*PT3	Trap Standing (Upper Limb)	Mixed	SG-U	125	Day 1 – 75 Targets Day 2 – 50 Targets	15 sec

\*Non-Paralympic Event

6.1.3 Shotgun Events will be conducted in accordance with ISSF Rules.

### 6.2 Shooting position

#### 6.2.1 Sport Class SG-S

6.2.1.1 Athletes in Sport Class SG-S must compete seated in a wheelchair or on a stool.

6.2.1.2 If seated in a wheelchair athletes must sit with the spine against the backrest of the wheelchair. Strapping to the backrest is allowed. The buttocks must remain in full contact with the seat of the wheelchair throughout the movement.

6.2.1.3 The feet must rest on the footplate of the wheelchair, or the lower limb must be supported by a leg rest with knees bent to a 90-degree angle or the angle indicated on the athlete’s Classification card. The feet must not be placed on the ground hereby enlarging the support base of the athlete as created by the standard wheelchair configuration.

- 6.2.1.4 If the athlete uses a stool the feet must support the weight bearing in a vertical plane to the stool, unless anatomical restrictions do not allow this. Such restriction must be recorded on the athlete's Classification Card. The buttocks of the athlete must remain in full contact with the stool throughout the movement.
- 6.2.1.5 Athletes in Sport Class SG-S must be watched by the Competition Jury or another delegated official to ensure that throughout the shot, the athletes remain seated, the spine is in contact with the backrest of the wheelchair (if seated in a wheelchair) and the feet adhere to the requirements outlined above.
- 6.2.1.6 Athletes in Sport Class SG-S may use strapping on their upper body to ensure safety while firing. The strapping used must not exceed 10 cm in width and must not be elastic. As much body weight may be supported by the strapping as the athlete determines is necessary.

#### 6.2.2 Sport Class SG-L

- 6.2.2.1 Athletes in Sport Class SG-L must compete in the standing position.
- 6.2.2.2 No stool, gadget or any device to support standing is permitted.

#### 6.2.3 Sport Class SG-U

- 6.2.3.1 Athletes in Sport Class SG-U must compete in the standing position.
- 6.2.3.2 No stool, gadget or any device to support standing is permitted.

### 6.3 Loading device (safety)

- 6.3.1 Athletes competing in Sport Class SG-U must use the adaptive loading stand, as set up by the LOC, on each station on the field.
- 6.3.2 During Athlete Evaluation, a Classification Panel may identify circumstances in which an individual athlete may not be able to, for example, safely load, hold and/or fire a shotgun. In such cases, the Classification Panel will report to the Competition Jury who will conduct a full investigation to determine if the use of an approved prosthesis and/or an adaptive loading stand will alleviate the safety concerns and enable the athlete to compete. If the Competition Jury determine that the athlete is unable to safely load, hold and/or fire a shotgun that athlete will not be eligible to compete in Shotgun Events.



6.3.3 For the avoidance of doubt, if the Classification Panel considers it necessary to disclose medical diagnostic information to the Competition Jury for the purposes of an investigation in accordance with Rule 6.3.2 above, such information shall be treated as confidential in accordance with the data protection provisions of the WSPS Classification Rules and Regulations.

#### **6.4 Other**

- 6.4.1 Except as provided for in Rule 6.3 above, adaptive devices used by athletes must be approved by WSPS. All adaptive devices will be inspected, and, if approved will be noted as a permanent approval of the device on the athlete's license.
- 6.4.2 No trigger adaptations are permitted for athletes competing in Shotgun Events.
- 6.4.3 Shooting tables and support stands are not permitted for athletes competing in Shotgun Events.

## 7 Vision Impaired (VI) Rules

### 7.1 Events and times

7.1.1 All VI Events and times are in accordance with these Rules and Regulations.

7.1.2 WSPS Recognised Competitions may comprise the following VI Events (the “VI Events”):

Event	Discipline	Gender	Class	Shots	Time	Time
					Electronic Targets	Target carriers & pit-operated Competitions
*VIS	10m Air Rifle Standing	Mixed	SHVI	60	1:15	1:30
*VIP	10m Air Rifle Prone	Mixed	SHVI	60	0:50	1:00

\*Non-Paralympic Event

7.1.2.1 It is recommended that in VI Events at least every third firing point is left vacant to avoid the disturbance of other athletes. The final decision on this matter will be made by the Technical Delegate.

7.1.2.2 No unused equipment or additional chairs may be left on the field of play. Athletes may not use chairs to rest their equipment on.

### 7.1.3 Finals

7.1.3.1 The ISSF Rules regarding timings of Events will be followed in all Finals, unless specified by WSPS. Please refer to the ‘WSPS Finals Commands’ document available on the WSPS website.

7.1.3.2 In VIS and VIP, the athlete must complete the loading process within ten (10) seconds from the command “LOAD” being given.

7.1.3.3 The last ten (10) seconds will be announced by the Competition Jury with the command (“ten”).

7.1.3.4 The VI Assistant must stay in position for the duration of the Finals.

## 7.2 Apparel and Equipment

### 7.2.1 Shooting Jackets

7.2.1.1 WSPS Rule 3.2.1 will apply.

7.2.1.2 VI Rifle athletes may use an ISSF-approved jacket in accordance with the ISSF Rules, in the following circumstances:

Position	Style	Regulation
<b>Prone</b>	Shooting from a Shooting Chair	Permitted: only the top three (3) jacket buttons may be fastened and the buttons may not extend below the bottom of the ribcage or equivalent. Any additional buttons must not be used
<b>Standing</b>	Shooting free-standing	Permitted: Jacket usage as per ISSF Rules

## 7.2.2 Shooting Trousers

7.2.2.1 Shooting Trousers are prohibited for all prone athletes.

## 7.2.3 Shooting Shoes

7.2.3.1 Shooting Shoes must follow ISSF Rules and WSPS Rule 3.2.3

## 7.2.4 Equipment

7.2.4.1 No additional light on the target is required; all lighting must follow ISSF Rules.

7.2.4.2 Competition Jury members must test the IR LED system. If a unit fails or is broken it is an allowable Malfunction.

7.2.4.3 The athlete must bring their own LED for the Competition.

7.2.4.4 During Qualification and Finals, all competing athletes must wear an eye covering which completely covers the eyes and ensures no vision is possible, such as opaque goggles, completely enclosed glasses, safety glasses or a mask deemed suitable by WSPS.

7.2.4.5 The sound unit of the athlete is not permitted to produce sound outside of the headphones. Audible noise from one (1) meter away is prohibited.

## 7.2.5 Equipment Control

7.2.5.1 Team Leaders and coaches are responsible for ensuring that the athlete has equipment and apparel that comply with these Rules and Regulations.

- 7.2.5.2 ISSF equipment will be checked in accordance with the ISSF Rules.
- a) VI Shooting specific equipment checks will be done in accordance with these Rules and Regulations.
  - b) The athlete is responsible for submitting VI Shooting-specific equipment and apparel for official inspection and approval before the start of every Competition. As part of this process:
    - I. the athlete must present both their current ID Card and WSPS License; and
    - II. the ‘Equipment Control Sheet’ (Appendix 5) must be completed and signed by all relevant parties.

7.2.5.3 Each athlete and their VI Shooting-specific equipment may be checked by the Competition Jury on the Firing Line prior to the start of each Event.

7.2.5.4 Random equipment checks will be done by the Competition Jury from Equipment Control following the Competition.

## 7.2.6 Non-allowable Malfunctions

7.2.6.1 A claim that there is a Malfunction of the aiming system must be immediately reported to the range staff.

7.2.6.2 Range staff will check the following during Competition:

- a) disconnected wires.
- b) low power bank or battery pack.

7.2.6.3 All other situations regarding Malfunctions of the aiming system will be dealt with in accordance with the ISSF rules.

## 7.2.7 Shooting Chairs & Table for Prone Position

7.2.7.1 Use of a backrest in the shooting position is prohibited.

7.2.7.2 For the prone position, it is not allowed to have a Shooting Chair with arm rests or sideboards.

7.2.7.3 WSPS Rules 3.8.1.1 to 3.8.1.6 will be applied.

## 7.3 Shooting Positions

### 7.3.1 Prone

7.3.1.1 WSPS Rule 4.2.2.5 will apply.

### 7.3.2 Standing

- 7.3.2.1 Athletes must be free-standing conforming to ISSF Rules.
- 7.3.2.2 The cheek must be used as described in the ISSF Rules.
- 7.3.2.3 The barrel of the rifle must be level with the shoulders of the athlete.
- 7.3.2.4 It is not necessary that the cheek is touching the cheek piece.

## 7.4 VI Assistant

7.4.1 VI Assistants are permitted only as described in the VI Shooting Appendix three (3) to the WSPS Classification Rules and Regulations.

7.4.2 The VI Assistant:

- 7.4.2.1 must place the LED lights on the target a minimum of fifteen (15) minutes before the call to the Firing Line;
- 7.4.2.2 verbal communication between the athlete and the VI Assistant is prohibited during the Competition. The VI Assistant is permitted to give non-verbal signals during the match for score indication and to show the direction of their target;
- 7.4.2.3 may adjust the sights at the request of the athlete and is not allowed to support the rifle. Only one (1) person may be touching the rifle during aiming; and
- 7.4.2.4 must stand in position for the duration of the Events (VIP & VIS) and it is not permitted to move between shots. The VI Assistant position (behind the athlete) is fixed according to the rules and cannot be changed. The VI Assistant must stand at a minimum of 50cm behind the athlete and may only move to give the signals for the score of the athlete.

7.4.3 A VI Assistant may:

- 7.4.3.1 assist the athlete with set up of equipment including the aiming device; and
- 7.4.3.2 immediately notify an athlete if they are not pointing at their own target.
- 7.4.3.3 An VI Assistant is only permitted to load if allowed in accordance with the terms of their WSPS Classification card.

## **8 Team Event Rules**

### **8.1 Events and format**

- 8.1.1 There will be team Events in each Event as numbers permit, except for at the Paralympic Games.
- 8.1.2 Team scores will be calculated by adding the individual Event scores of the athletes within a team together (i.e. no separate team matches will be shot).
- 8.1.3 Only an athlete entered as a 'Full' participant may compete in team events. Athletes entered as MQS only may not participate.

### **8.2 Team size**

- 8.2.1 All teams must consist of three athletes.

### **8.3 Maximum number of teams per NPC**

- 8.3.1 WSPS Sanctioned Competitions and WSPS Championships: only one team per event per NPC.
- 8.3.2 WSPS Approved Competitions: maximum two teams per event per NPC.

### **8.4 Event viability**

- 8.4.1 Minimum three teams must be on the start list of that Event (by the final entries deadline); otherwise the team Event is automatically cancelled.
- 8.4.2 If only three teams participate in the Event, medals will be awarded according to the 'minus-one' rule (e.g. only gold and silver would be awarded).

### **8.5 Mixed Team**

- 8.5.1 Maximum of two teams per event per NPC. Please refer to Appendix 11.

## 9 Medical Rules

### 9.1 Return to Field of Play Decisions

- 9.1.1 The overriding priority at all times is to safeguard the health and safety of athletes. The outcome of the Competition should never influence such decisions.
- 9.1.2 It is the responsibility of the team management to evaluate whether a sick or injured athlete is fit to continue in or return to the Competition. WSPS may delay or prevent any athlete from entering or participating in any Competition on the basis of the health, safety or security of any athletes or other participants, at its absolute discretion.

### 9.2 Epilepsy

- 9.2.1 It is the duty of all athletes and their NPCs to declare to WSPS if the athlete has ever suffered any form of epileptic fit/seizure or epilepsy-related episode.
- 9.2.2 All athletes must complete the 'Athlete Epilepsy Declaration Form' (**Appendix 9**) which must be uploaded to the athlete's SDMS profile before they are eligible to have a WSPS License for the Competition season.
- 9.2.3 The 'Athlete Epilepsy Declaration Form' confirms if the athlete has epilepsy, and if so, that the epilepsy is stable, and identifies what type of epilepsy the athlete suffers from.
- 9.2.4 If an athlete declares that he/she has been medically diagnosed with epilepsy and has had an epileptic episode in the preceding 12-month period, the athlete's participation in WSPS Recognised Competitions shall be subject to approval by WSPS.
- 9.2.5 If at any time an athlete suffers any form of epileptic fit/seizure or epilepsy-related episode, an updated 'Athlete Epilepsy Declaration Form' must immediately be submitted to WSPS.

### 9.3 Pacemakers

- 9.3.1 The use of pacemakers by athletes in WSPS Recognised Competitions is subject to approval by WSPS.
- 9.3.2 Any athlete that uses a pacemaker is required to submit a medical file to WSPS ([info@worldshootingparasport.org](mailto:info@worldshootingparasport.org)), detailing the pathology and technical details of the device implemented.



- 9.3.3 The WSPS shall determine whether the device is approved, and this decision is final. The athlete will only be entitled to use this approved device, and any change must be notified to WSPS immediately.
- 9.3.4 Failure to notify WSPS of the use of a pacemaker results in automatic disqualification of the athlete and any results obtained in Competition where a pacemaker was used.



**World Shooting Para Sport**

Adenauerallee 212-214  
53113 Bonn, Germany

Tel. +49 228 2097-200  
Fax +49 228 2097-209

**[info@WorldShootingParaSport.org](mailto:info@WorldShootingParaSport.org)**  
**[www.WorldShootingParaSport.org](http://www.WorldShootingParaSport.org)**

© 2022 World Shooting Para Sport – ALL RIGHTS RESERVED  
Photo ©: Hiroki Nishioka